

TECHNICAL REPORT 1

LIGHTING EXISTING CONDITIONS AND DESIGN CRITERIA



SMC Campus Center

Baltimore, MD

Submitted: 10/4/2010

AGi32 Calculation Files:

User ID: jlw5152

P:\Thesis\

Ballroom.agi

Classroom.agi

Executive Summary

The following presents a graphical and detailed analysis of the existing lighting systems of the SMC Campus Center in Baltimore, MD. Of the 110,000 square feet of educational and recreational space, the analysis focuses on four different types of spaces, which include a large work space (3rd floor classroom), a special purpose space (2nd floor ballroom), a circulation space (main lobby), and an outdoor space (north building facade). The documentation for each space will include (1) existing conditions with descriptions, activities, plans, elevations, sections, finishes, and materials, (2) design considerations and criteria, and (3) an evaluation and critique of the existing lighting design.

Fundamental goals of the architect are to increase interaction between students and faculty from the various UMB schools and to develop an interactive campus community. The lighting design of the Campus Center attempts to enhance the modern student centered facility by using a mixture of energy efficient and decorative luminaires. Generally, the lighting is successful in creating environments which promote interaction and bring occupants together. The design for all spaces was conducted based off of IESNA lighting recommendations and ASHRAE 90.1-2004 energy code requirements.

Although, the current lighting design solutions are sufficient in most spaces, there is room for improvement. Illuminance level recommendations and lighting power densities are exceeded or barely met, even with additional allowances for decorative lighting. The Campus Center dimming system has a substantial opportunity for enhancing energy performance by advancing daylight integration and incorporating user-friendly control systems.

Table of Contents

Building Information and Statistics	3
Large Work Space Classroom	
Existing Conditions.....	4
Existing Lighting Conditions.....	6
Lighting Design Considerations and Criteria.....	7
Evaluation and Critique.....	10
Lighting Calculations for Current Design.....	11
Special Purpose Space Ballroom	
Existing Conditions.....	14
Existing Lighting Conditions.....	21
Lighting Design Considerations and Criteria.....	23
Evaluation and Critique.....	26
Lighting Calculations for Current Design.....	27
Circulation Space Main Lobby	
Existing Conditions.....	30
Existing Lighting Conditions.....	34
Lighting Design Considerations and Criteria.....	37
Evaluation and Critique.....	39
Outdoor Space Building Facade	
Existing Conditions.....	41
Existing Lighting Conditions.....	48
Lighting Design Considerations and Criteria.....	51
Evaluation and Critique.....	52
References	53

Building Information and Statistics

Located on the site of the previous Student Union Building, the SMC Campus Center is a modern student-centered facility that significantly improves student life at UMB through expanded programming and enhancement of the urban campus environment. The fundamental goals of the Campus Center are to increase interaction between students and faculty from the various UMB schools and to develop an interactive campus community. The exterior of the Campus Center is respectful to the materials and aesthetics of the adjacent buildings, while maintaining a unique, easily recognizable identity. The Campus Center provides openness to Lombard Street and adjoins the surrounding courtyard and plaza areas. The interior is designed to encourage health and wellness, house student organizations and services, provide recreation and relaxation, and offer exceptional food and dining venues.

Building Name: Southern Management Corporation (SMC) Campus Center

Location and Site: Baltimore, MD

Occupancy Type: Academic

Size: 110,000 SF

Stories Above Grade: 5 + penthouse

Primary Project Team:

Owner: University of Maryland, Baltimore

CM/PC: The Whiting-Turner Contracting Co. | Baltimore, MD

Architect: WTW Architects, Inc. | Pittsburgh, PA

Landscape Architect: Fluora-Teeter Landscape Architects, Inc. | Baltimore, MD

MEP Engineer: Henry Adams, LLC | Towson, MD

Structural Engineer: Whitney, Bailey, Cox and Mangini, LLP | Towson, MD

AV/IT/Security: Allen & Shariff Corporation | Columbia, MD

Interior Designer: Portnoy Levine Design Associates | Baltimore, MD

Aquatics Designer: Counsilman/Hunsaker & Associates | St. Louis, MO

Elevator Consultant: Lerch, Bates & Associates, Inc. | Bowie, MD

Dates of Construction: May 2006 - May 2009

Overall Project Cost: \$43,400,000

Project Delivery Method: CM at Risk

Large Work Space | Classroom

Existing Room Conditions

Description

The 3rd floor classroom offers a flexible work space for student organizations and academic services. Tailored for both class discussions and conference meetings, the classroom is a viable solution when other assembly rooms in the Campus Center are too small to accommodate a larger group of people.

Furniture and Accessories

The classroom has various configurations depending on the activity that will occur in the space. Desks can be organized in rows for a typical classroom layout or in a U-shape for meetings and debates. A podium is located in the front of the room near the floor box (see Figure 1). A retractable projector is located in the center of room and a screen is also concealed in the front of the room in the ceiling.

Area 1,142 SF

Dimensions Approximately 36'-10" x 31'-6", with a ceiling height of 12'-0"

Activities/Tasks

The primary tasks are reading and writing for both classroom and conference room layouts. The reading and writing will be on horizontal surfaces such as desks because there is no vertical whiteboard present in the room. Presentations may also take place at the podium and be projected onto the retractable screen. Personal computers may be used for certain classes and meetings, so viewing of VDT screens will be another critical task for the classroom.

Materials





Surface	Material	Color	Reflectance
Ceiling	Acoustical Ceiling Panel: Armstrong, Cirrus Open Plan, 2'x4'x7/8", 9/16" grid	White 	0.85
Walls (N, E, W)	Paint: Benjamin Moore 2154-60	Filtered Sunlight 	0.83
Walls (S)	Paint: Benjamin Moore 1538	Wildwood Crest 	0.25
Floor	Carpet Tile: Mannington Variations - Stripes	Acorn 	0.07

Table 1: Classroom Finishes

Classroom Floor Plans and Section

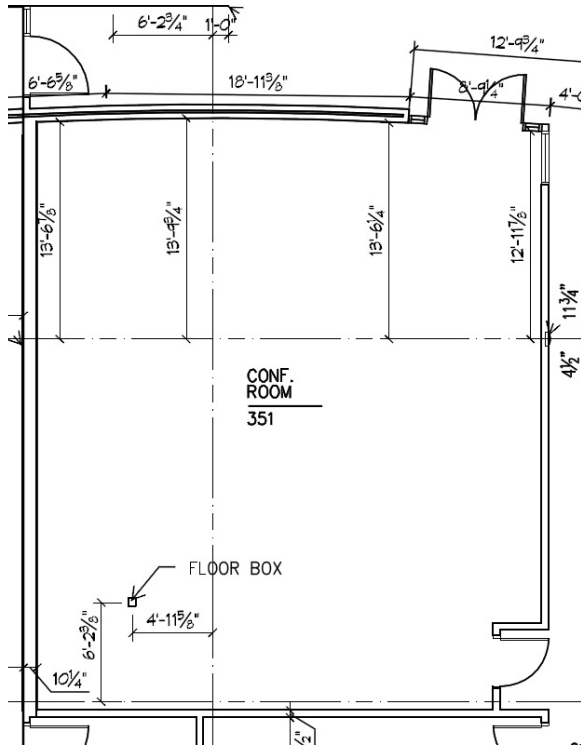

Figure 1: Classroom Floor Plan (NTS)

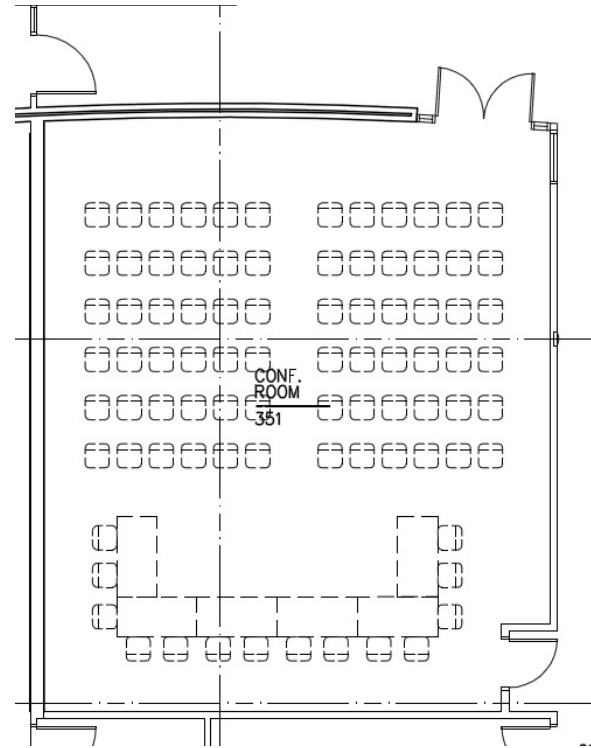

Figure 2: Classroom Furnishing Plan (NTS)

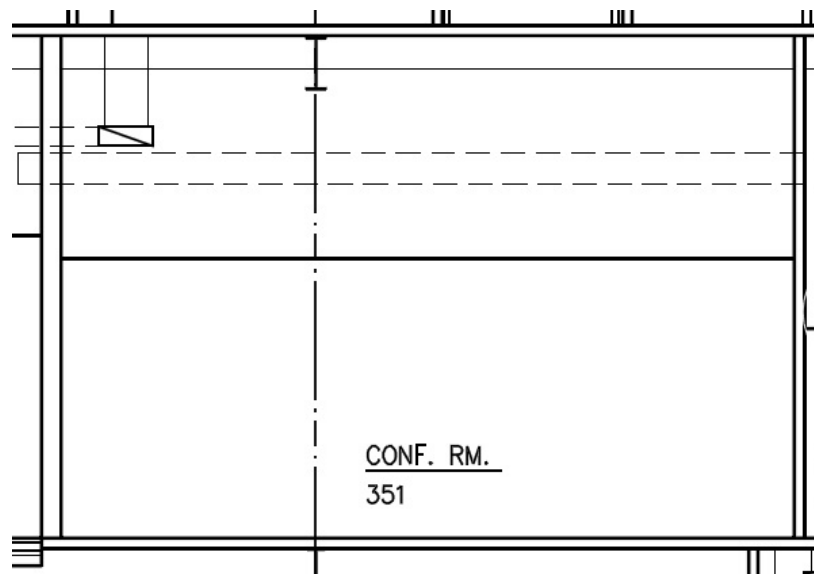

Figure 3: Classroom N-S Section (NTS)

Lighting Design Considerations and Criteria

IESNA Lighting Handbook Space Type

Educational Facilities, Classrooms, General (see Reading)

Specific Tasks:

- Reading: Photocopies
- Reading: VDT screens
- Reading: #2 pencil and softer leads
- Reading: Ball-point and felt-tip pens
- Reading: Printed 10-point and 12-point type
- Conference Room: Meeting

IESNA Illuminance Recommendations

Reading: Photocopies

- 30 fc (horizontal)

Reading: VDT screens

- 3 fc (horizontal)
- 3 fc (vertical)

Reading: #2 pencil and softer leads

- 30 fc (horizontal)

Reading: Ball-point and felt-tip pens

- 30 fc (horizontal)

Reading: Printed 10-point and 12-point type

- 30 fc (horizontal)

Conference Room: Meeting

- 30 fc (horizontal)
- 5 fc (vertical)

Psychological Impression

The classroom is meant to provide a positive environment by encouraging learning and interaction. The lighting design should enhance learning by promoting an open and public impression.

Design Implications

- Provide a uniform layout of luminaires in the room.
- Higher room surface luminances to appear brighter and open

System Control and Flexibility (Important)

The space is flexible, providing a large gathering area for classroom learning, projector presentations, and general meetings. Therefore, luminaires and controls should be selected to adjust illuminance levels for the multiple uses. Classrooms and meetings will generally require ambient lighting with emphasis on the presenter. Audiovisual presentations require a reduction in lighting for better viewing, but the room should not be completely darkened since note taking may be expected by the students. Lower general illuminance levels, especially vertical illuminance, are recommended when VDTs are utilized to maximize visibility of screens. A perimeter system may also assist with visual appeal and will allow for wall-mounted presentations.

Design Implications

- Consider dimming options to account for the various activities in the space with controls for general ambient, front of the room for presenter and screen, and perimeter for wall-mounted presentations.

Direct and Reflected Glare (Important)

An educational space must minimize glare to reduce discomfort and not impair vision. Since this is an interior classroom, problems from sunlight are automatically avoided and do not need to be addressed. The main problems of glare will be a result of reflections and visibility of the light sources. Shadows cast on tasks can also become annoying.

Design Implications

- Reduce reflected glare by making sure desks and other equipment are a matte finish.
- Avoid open luminaires with a potential direct view of the light source.
- Provide sufficient uniformity on the work plane to limit shadowing.
- Highly reflective finishes providing uniform levels of illuminance and brightness.

Light Distribution on Task Plane - Uniformity (Important)

Patterns of light on desks and tables can be distracting and confusing, especially in a classroom where the goal is to maintain focus and attention. A uniform distribution promotes better visibility, comfort, and perception.

Design Implications

- Work plane illuminances that are 1.5 to 3 times higher than surrounding areas to focus attention on the task.
- Avoid high luminance ratios that cause fatigue.
- Consider uniform photometric distribution patterns of luminaires.

Modeling of Faces or Objects (Important)

More inclined for conferences, meetings and presenters, it is important for the lighting to encourage occupant interaction. Interreflected light from reflective walls and ceilings will increase the vertical illuminance on faces during meetings, which will make people more comfortable and appear clear without unwanted shadows.

Design Implications

- Avoid concentrated downlighting, which creates harsh facial shadows.

Luminance Ratios (Important)

The brightness of surfaces within the field of view must be considered and kept within acceptable limits to limit eye fatigue. If the difference is great, students will be distracted by discomfort and slower visual performance.

Design Implications

- Limit luminance of luminaires to increase luminance of all interior spaces.
- Normally viewed surface-to-task (5:1), Desks (at least 1/3 visual task luminance)

Illuminance (Horizontal and Vertical) (Very Important)

As illuminance is important for most spaces, it is crucial in classroom lighting for occupants to carry out specific tasks comfortably without complaints of poor lighting in the room. Usually, the most difficult commonly occurring task will be selected and provided with an appropriate level of lighting. Because the space is multifunctional, it is important to also be able to change light levels for specific tasks, while considering horizontal and vertical surfaces that will require light.

Design Implications

- Provide a flexible lighting solution for all functions of the classroom.
- Provide simple lighting controls for occupants to manually adjust lighting levels.

ASHRAE 90.1 - 2004 Power Density Allowance

Space-by-Space Method (Table 9.6.1)

- Conference/Meeting/Multipurpose: 1.3 W/SF
- Classroom/Lecture/Training: 1.4 W/SF

Room Area: 1,142 SF

Lighting Power Allowance: 1485 W

Evaluation and Critique

The existing lighting design in the classroom meets only a few of the design considerations and criteria detailed in the previous pages. The IESNA Handbook recommends an average work plane illuminance of 30 fc for classroom and meeting tasks and activities. Currently, the average desk illuminance is an extremely high 72 fc with good uniformity. This assumes all three lamps from each luminaire are fully on, even though this may never occur because of the classroom's dimming control options. No tasks in the classroom should ever require more than 50 fc, so the space is severely over-illuminated.

Over-illumination affects other considerations for the classroom as well. Each luminaire is an open parabolic with the potential for direct viewing of the T8 lamps at certain angles which can be distracting and annoying. Reflected glare could also be problematic from the louvers of the luminaire or the reflective walls. Luminaire luminance is extremely high, making the ceiling luminance appear much greater than the surrounding surfaces. This will cause eye fatigue and cause viewing discomfort and poor visual performance for completing tasks. The lighting solution also fails to meet the ASHRAE 90.1-2004 power density requirements, although the value is close.

The classroom is equipped with an 8-scheme and manual control Lutron dimming system. Each row of lights is modifiable to adjust for the various functions. The light over the podium is controlled separately as well to highlight the presenter. The solution provides good uniformity, which aids in visual comfort, but the high illuminance causes more distractions.

Classroom Lighting Power Density			
Type	Quantity	Input W/Luminaire	Total Watts
A3	17	93.5	1589.5
B3	1	57.2	57.2
Total Watts			1646.7
Total SF			1142
LPD			1.44 W/SF

Table 3: Classroom LPD Calculation

Lighting Calculations for Current Design

Luminaire Designation	Maintenance Category	Cleaning Interval	Initial Lumens per Luminaire	Mean Lumens per Luminaire	LLD	LDD	RSDD	BF	Total LLF
A3	V	Clean 12 month	2800	2660	0.95	0.92	0.975	1.00	0.85
B3	V	Clean 12 month	1325	1260	0.95	0.92	0.975	1.00	0.85

Table 4: Classroom Light Loss Factors

Sample Light Loss Factor Calculations

Lamp Lumen Depreciation

F32T8/SP35/ECO

LLD = mean lumens / initial lumens = 2660/2800 = **0.95**

Luminaire Dirt Depreciation

*Using new procedure from IESNA Lighting Handbook, 10th edition

Environment – Clean

Luminaire – Other

Case – W

Chart value based on 12 month cleaning cycle = **0.92**

Room Surface Dirt Depreciation

Room Cavity Ratio = $[(5 \times 9.5) \times (36.8 + 31.5)] / [(36.8 \times 31.5)] = 2.65$

Degree of dirt condition – Clean

Cleaning Cycle – 12 months

Expected dirt depreciation = 12%

Luminaire distribution type – Direct

RSDD = **0.975**

Ballast Factor – Lutron Hi Lume for 32W T8 = **1.0**

AGi32 Calculation Summary

2'-6" Work Plane (Desks)	
Average Illuminance (fc):	71.85
Maximum Illuminance (fc):	88.80
Minimum Illuminance (fc):	40.70
Maximum : Minimum:	2.18
Uniformity:	1.34

Table 5: Work Plane Calculations

AGi32 Calculations and Renderings

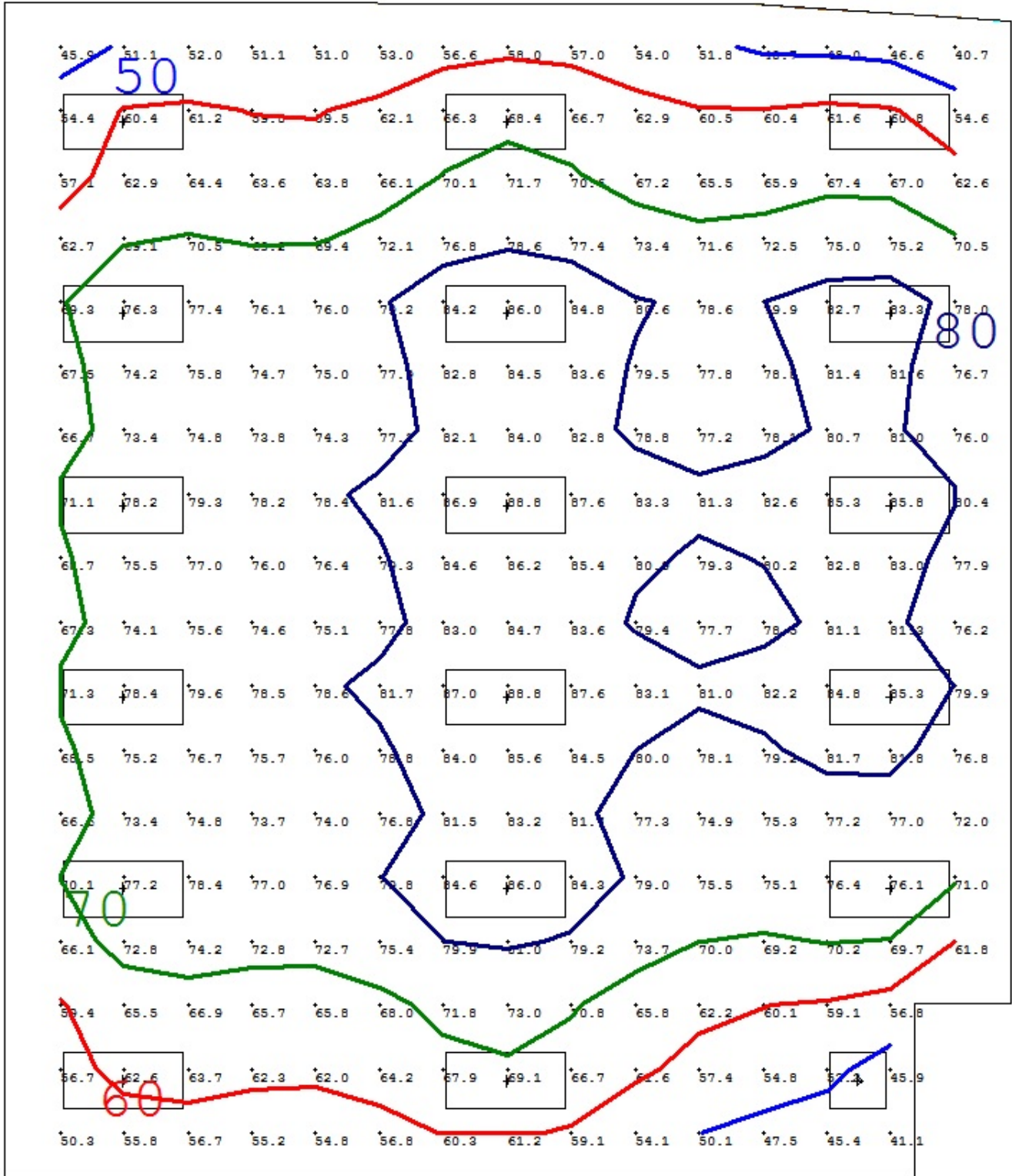

Figure 5: AGi32 Work Plane Calculation Grid with Illuminance Contour Lines



Figure 6: Classroom Simulated Lighting Environment

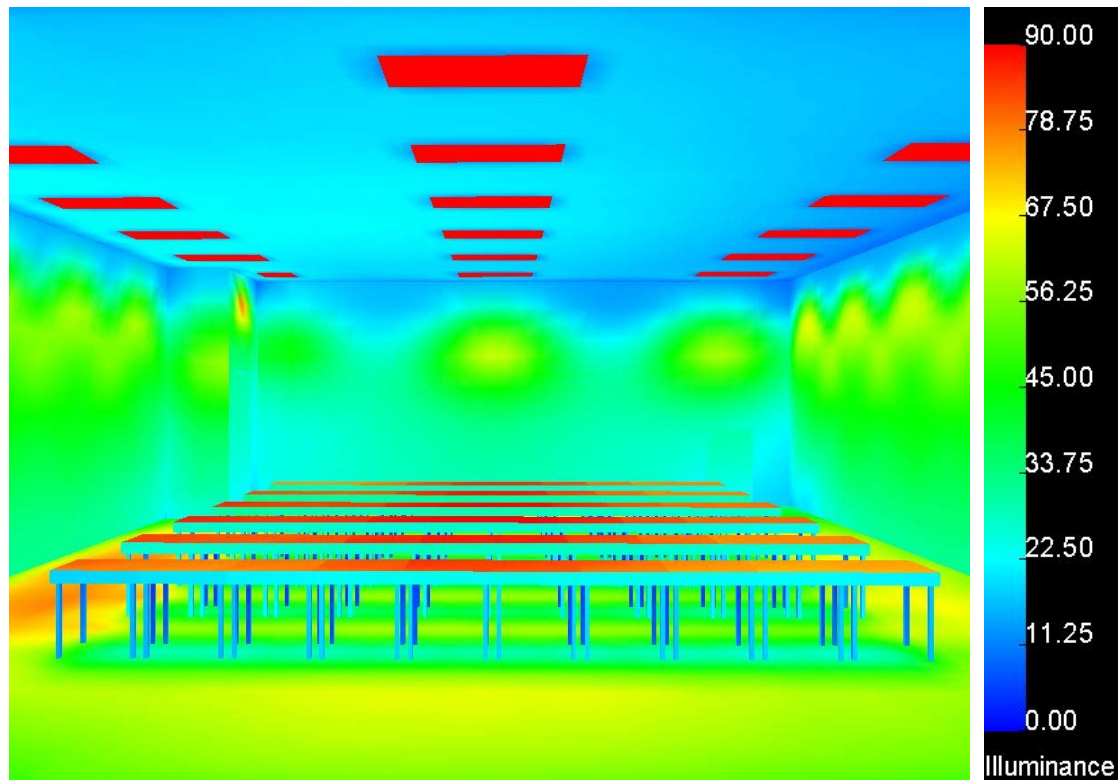

Figure 7: Classroom Pseudo Color Rendering

Special Purpose Space | Ballroom

Existing Room Conditions

Description

The 2nd floor ballroom is a large multifunctional space with a variety of uses for student and client events. A retractable partition divides the ballroom into two smaller areas. The ballroom is specially located between a pre-function lounge to the west and its own food preparation room to the east. The windows on the south wall provide an excellent view to Camden Yards and MT Bank Stadium.

Furniture and Accessories

The ballroom is designed to provide flexible configurations for social gatherings, banquets, meetings, fairs, and can also accommodate classroom-style and theatre-style seating arrangements (see Figures 9-13). Each area of the ballroom has a retractable projector and screen. Podiums and temporary stages are also available for use in the ballroom. Two flat screen televisions are located on the east and west walls of the ballroom to display campus announcements, information, and weather updates.

Area 4,292 SF

Dimensions Approximately 83'-2" x 51'-7", with a ceiling height of 15'-0" and 1'4" bulkheads

Activities/Tasks

There are a variety of activities and visual tasks that occur in the ballroom:

<u>Activity</u>	<u>Visual Tasks</u>
Banquet:	Dancing, eating, award presentations
Classroom:	Reading, writing, presentations
Theatre:	Presentations, movies
Fairs:	Displays, presentations

In order to take all of the visual tasks into considerations, system control and flexibility will be very important to suit the needs and lighting levels of the different events.

Materials









Surface	Material	Color		Reflectance
Ceiling	Acoustical Ceiling Panel: Armstrong, Ballroom Field - 2'x2'x3/4"	White		0.85
Ceiling	Acoustical Ceiling Panel: Armstrong, Ballroom Accent - 2'x2'x3/4"	White		0.85
Ceiling (bulkheads)	Paint: Benjamin Moore 2154-60	Filtered Sunlight		0.83
Walls (N, E, S, W)	Wallcovering: JM Lynne Davino J324-107	Sicilian Umber		0.77
Walls (N, E, W)	Acoustical Panel: Panel Fabric-Maharam Tek-Wall 395940	Papyrus		0.88
Pilasters	Paint: Benjamin Moore 1538	Wildwood Crest		0.25
Pilasters/Base	Wood Trim	Medium Maple		0.13
Floor	Carpet Broadloom: Less Thought Pattern Custom Sample Style #P1039, Sample 50022 07901	Custom		0.17

Table 6: Ballroom Finishes

Ballroom Floor Plans, Elevations, and Section

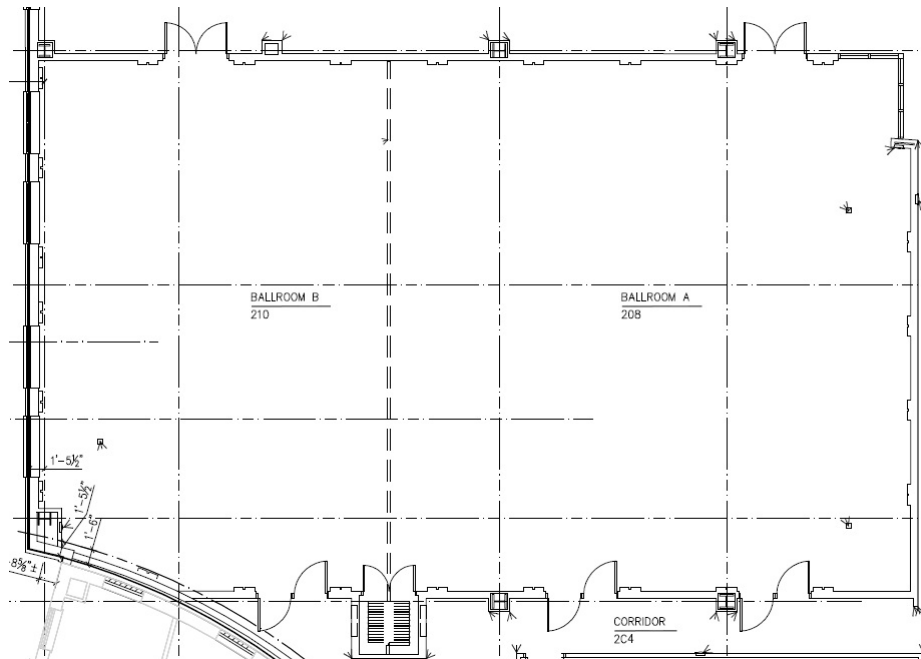

Figure 8: Ballroom Floor Plan (NTS)

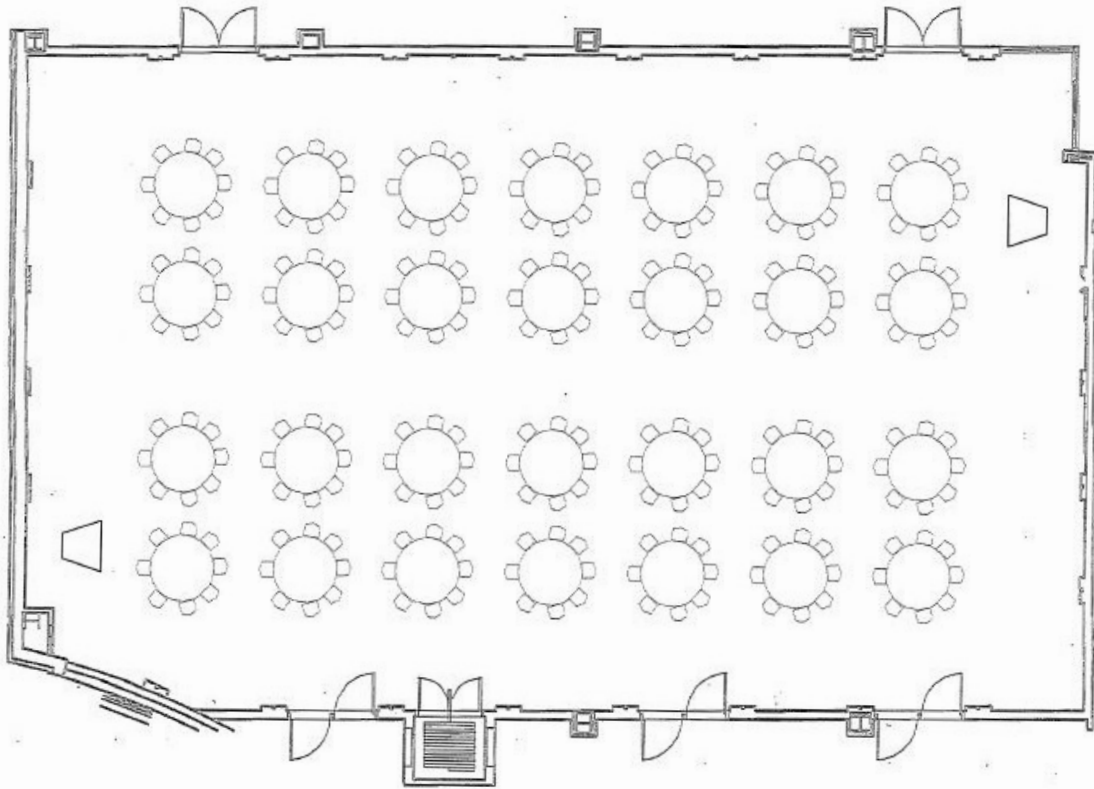

Figure 9: Ballroom Banquet Layout

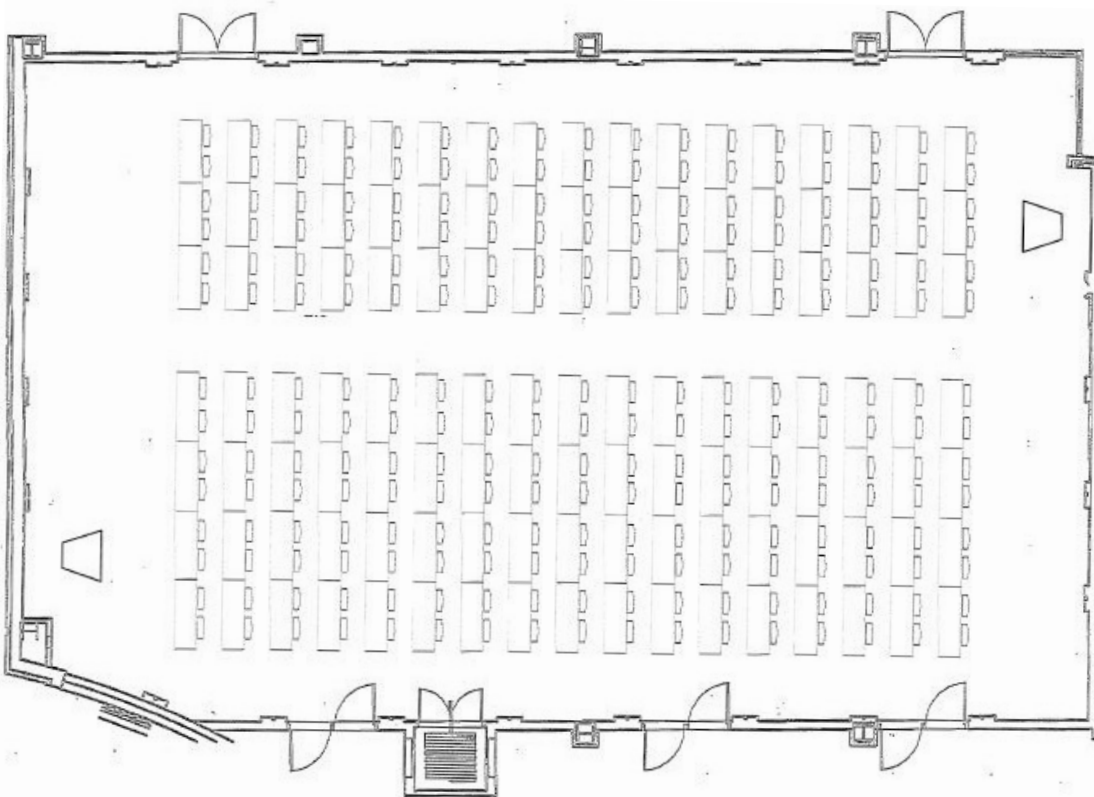

Figure 10: Ballroom Classroom Layout

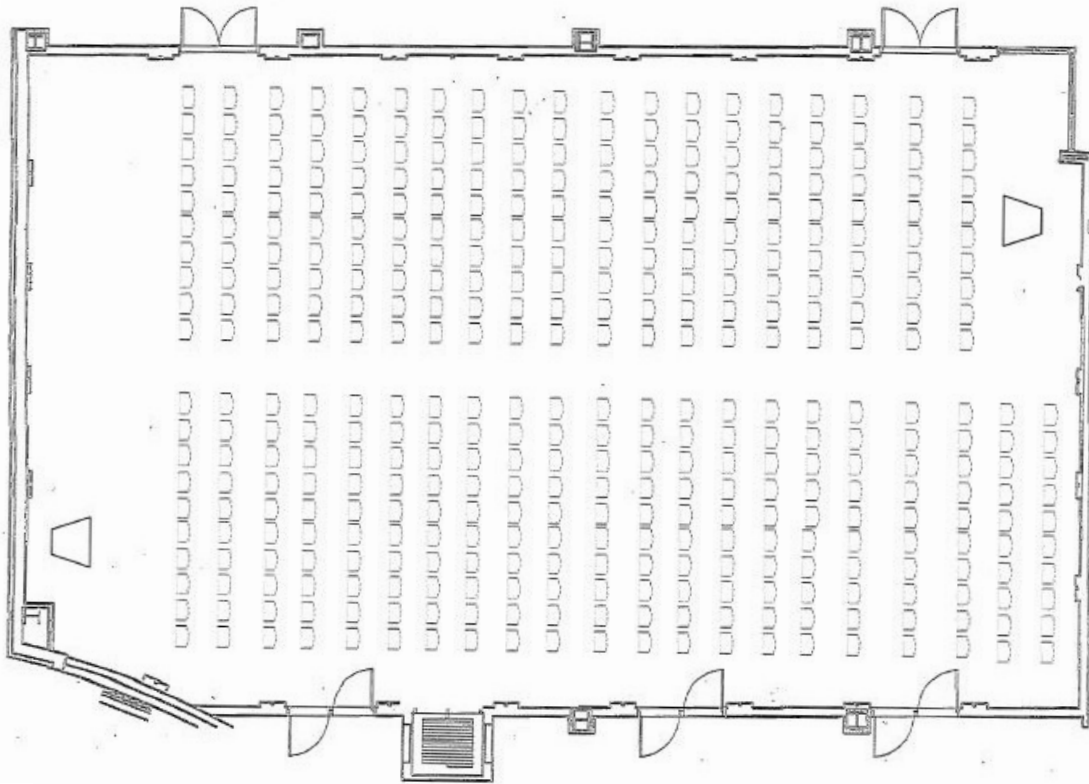

Figure 11: Ballroom Theatre Layout

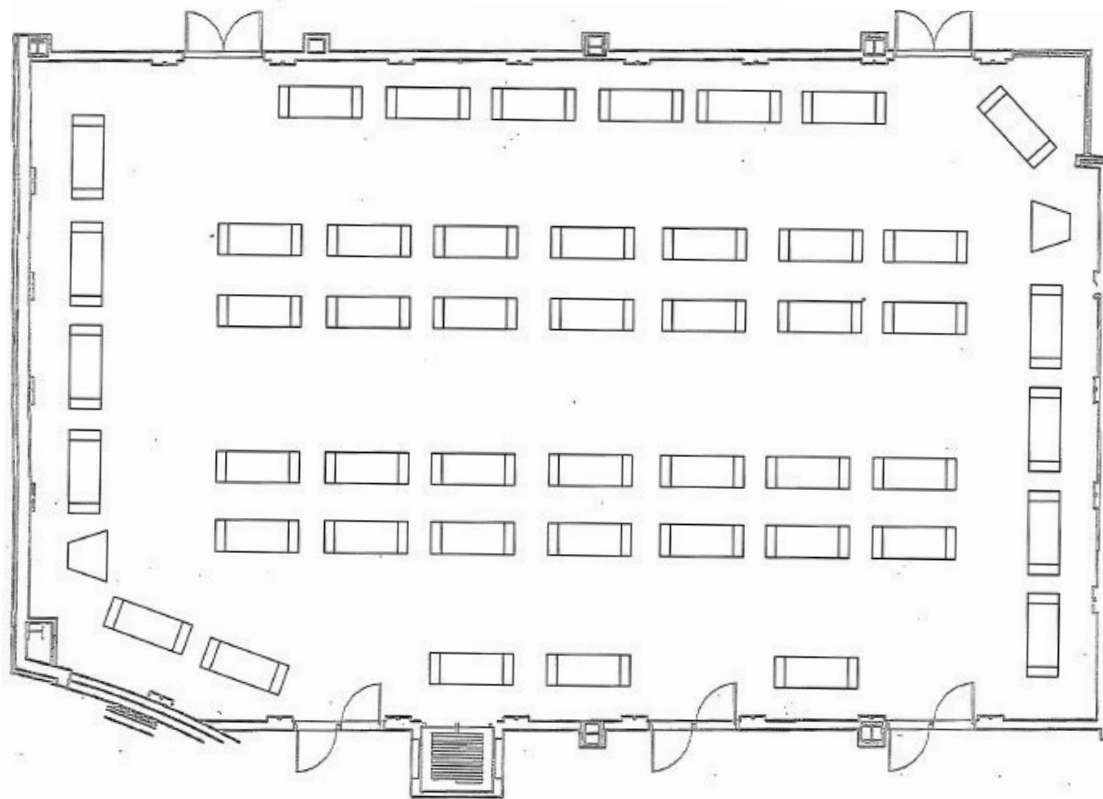

Figure 12: Ballroom Fair Layout

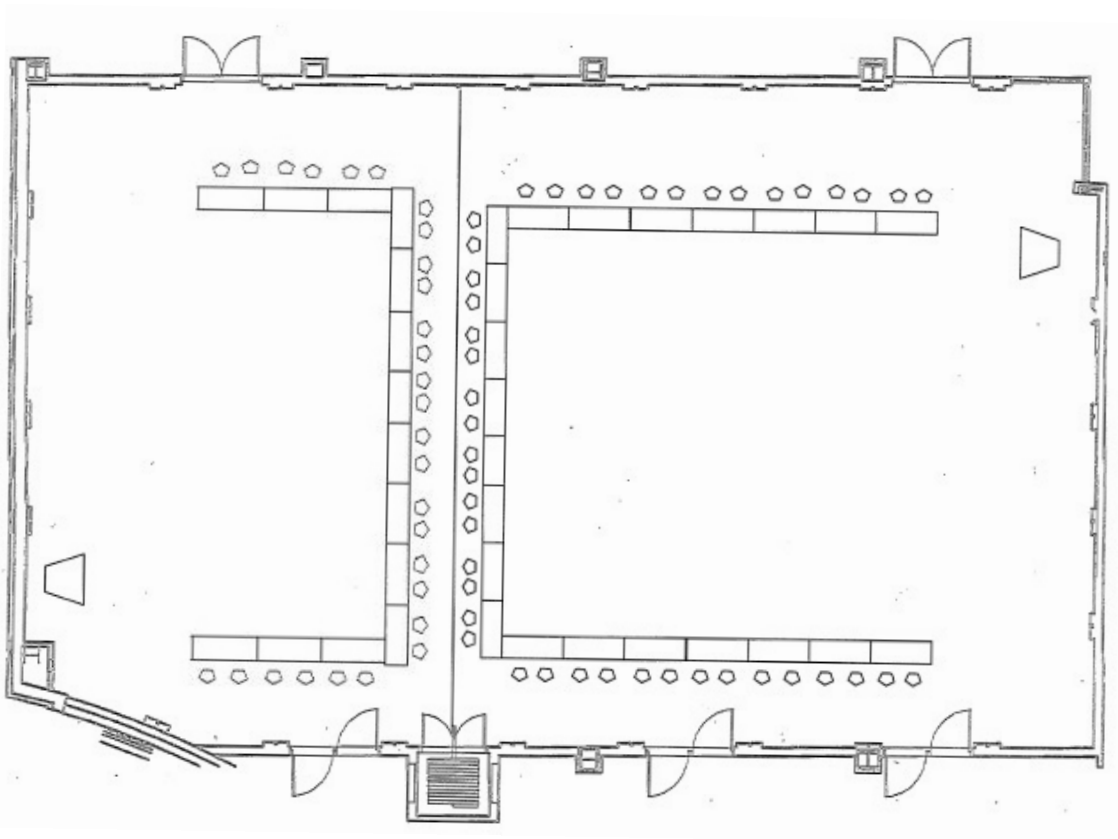

Figure 13: Ballroom Meeting Layout

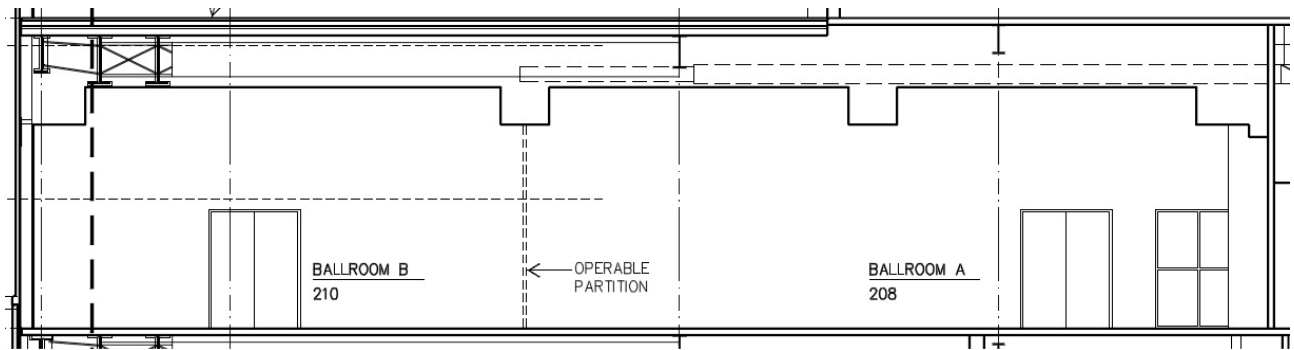

Figure 14: Ballroom N-S Section (NTS)

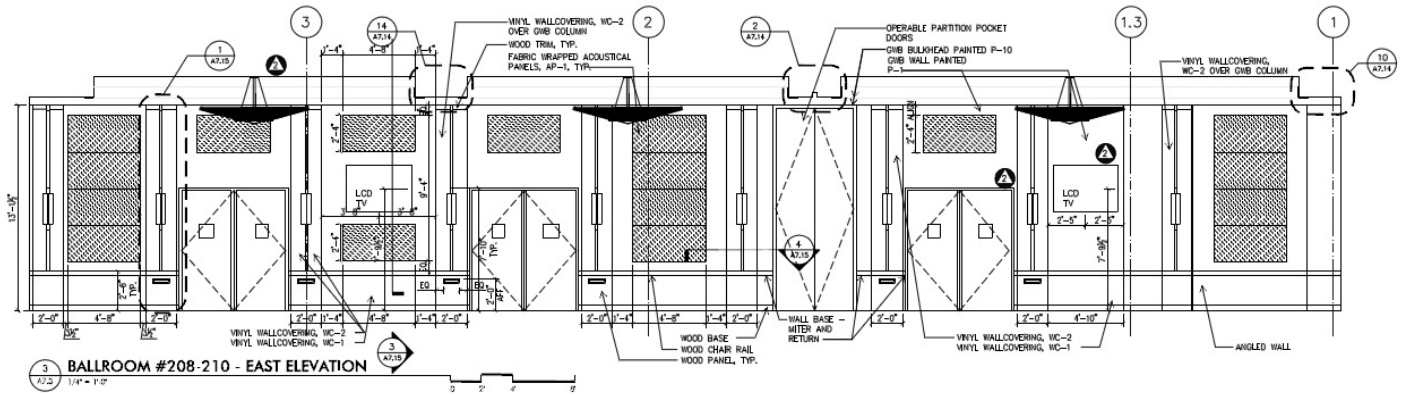

Figure 15: Ballroom East Elevation (NTS)

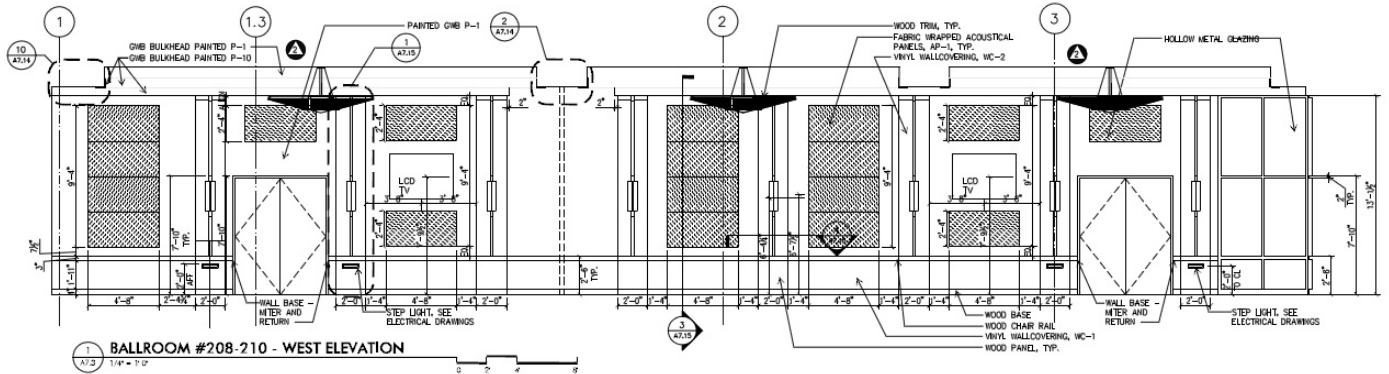

Figure 16: Ballroom West Elevation (NTS)

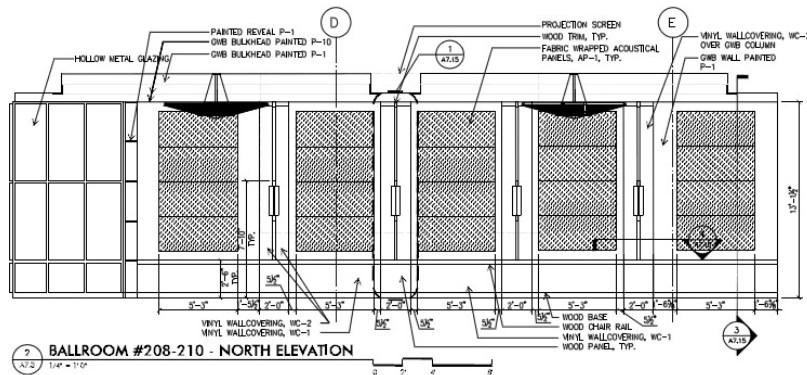

Figure 17: Ballroom North Elevation (NTS)

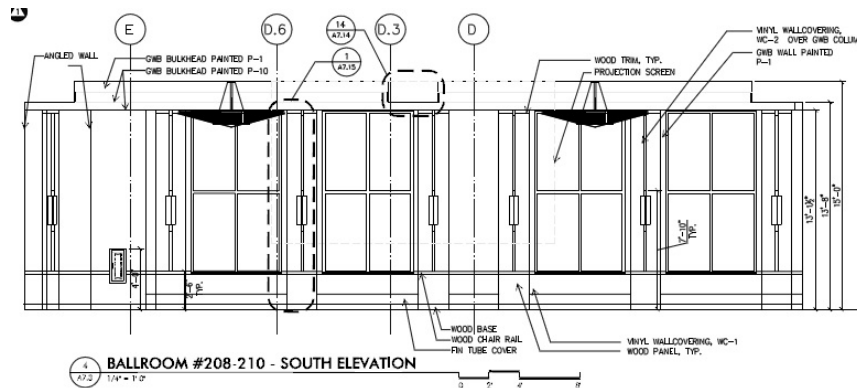

Figure 18: Ballroom South Elevation (NTS)

Ballroom Photographs

Figure 19: Ballroom looking South



Figure 20: Ballroom looking North

Existing Lighting Conditions

Lighting Layout

The lighting for the ballroom is comprised of custom decorative pendants and wall sconces, ceiling recessed downlights, wall washers and spotlights, and wall recessed step lighting luminaires. Compact fluorescents are used for the downlights, wall washers, step lighting, and custom pendants. Other light sources include halogen IR for the spotlights and linear fluorescent for the custom wall sconces.

Lighting Equipment

An 8-scene dimming controller with raise/lower and on/off control is located in each corner of the ballroom (highlighted in red on Figure 21). A single partition control station is located on west wall (highlighted in green on Figure 21). All luminaires, excluding the step lights, are connected to a 208Y/120V dimming panel and are powered with a Lutron Hi-Lume (1%) dimming ballast and interface with the Lutron Grafik Eye dimming control unit.

Type	Mounting	Luminaire Description	Manufacturer and Catalog Number	Lamp Number and Type	Voltage
C4D	Ceiling Recessed	8" aperture open reflector downlight with clear reflector and a semi-diffuse low iridescent finish and Lutron Hi-Lume dimming ballast	Gotham Lighting AFV-42TRT-8AR-LD-HILUME	(1) 42W TRT CFL	120
C4DW	Ceiling Recessed	8" aperture open reflector wall wash downlight with clear reflector and a semi-diffuse low iridescent finish and Lutron Hi-Lume dimming ballast	Gotham Lighting AFVW-42TRT-8AR-LD-HILUME	(1) 42W TRT CFL	120
D	Wall Recessed	12.75" wide, 3.2" tall, 4" deep recessed low level step luminaire with stainless steel faceplate and tempered glass lens	Bega Lighting 2032P-120	(1) 13W Twin CFL	120
Q	Ceiling Recessed	Precision module with two cells of the PAR38 lamp, 10" wide by 18" long	Modular International M2J1-PV-REC-TR-PAR38	(2) 100W PAR38 HIR	120
W2	Pendant	6' x 6' custom pyramidal luminaire with opal acrylic glass panels	Winona Lighting Custom Type 5	(8) 42W CFL	120
WAD	Wall Surface	2' x 1' custom wall sconce with opal acrylic glass	Winona Lighting Custom Type 3D	(2) 17W T8 Fluorescent	120

Table 7: Ballroom Existing Lighting Equipment

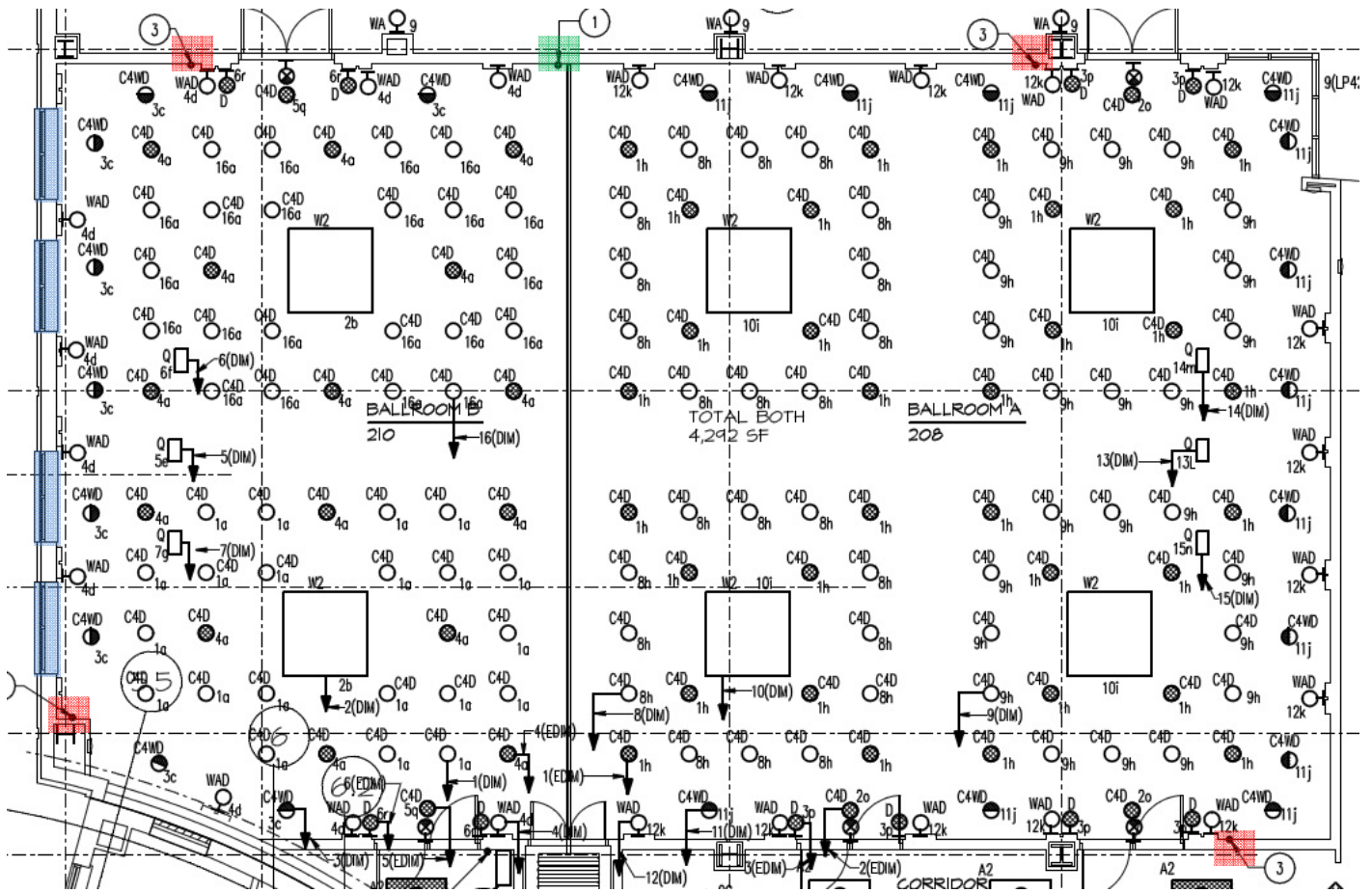

Figure 21: Ballroom Lighting Plan (NTS)

Daylighting

Four large windows on the south wall (highlighted in blue on Figure 21) provide daylight into the ballroom. Because, there are no obstructions or other buildings that prohibit sunlight from entering the space, daylight will be present for the majority of operating hours. There are currently no daylight control devices in place in the ballroom. The south façade has the best views of downtown Baltimore, including Oriole Park at Camden Yards and M&T Bank Stadium.

Lighting Design Considerations and Criteria

IESNA Lighting Design Guide Space Type

Dance Halls/Discotheques, Ballrooms/social events

Specific Tasks:

- Ballrooms/social events
- Meeting
- Exhibit cases, 3-dimensional objects
- Classroom

IESNA Illuminance Recommendations

Ballrooms/social events (Banquets and Social Gatherings)

- 5 fc (horizontal)
- 3 fc (vertical)

Meeting (Conference Room)

- 30 fc (horizontal)
- 5 fc (vertical)

Exhibit cases, 3-dimensional object (Fairs)

- 30 fc (horizontal)
- 5 fc (vertical)

Classroom (General)

- 30 fc (horizontal)

Psychological Impression

The lighting design in the ballroom can promote multiple psychological impressions depending on the function taking place. Classes, meetings, and fairs will be more open and public, while banquets and dinners can be more intimate and private.

Design Implications

- Provide adequate controls to adapt lighting levels to the specific function.
- Consider multiple lighting arrangements, including general downlighting, peripheral emphasis, and decorative to include all the needs of the various functions.

Appearance of Space and Luminaires (Very Important)

The ballroom is the most decorative space in the Campus Center. Large custom pendants and wall sconces mimic the theme of the lobby, while colored pilasters with wood trim and bulkheads distinguish the architecture of the space. It is very important for the lighting equipment to display the architecture, enhance the design, and be flexible because the ballroom is used with a variety of furnishings, from large tables for banquets to desks for meetings. Visual clutter of luminaires should be avoided to evade distractions.

Design Implications

- Select lighting equipment that will enhance the space functionally and decoratively.
- Due to the flexibility of the space, consider multiple lighting arrangements and control schemes to meet the lighting levels and impressions of the various functions.

System Control and Flexibility (Very Important)

Due to the wide variety of functions that can occur in the ballroom, it is crucial for the lighting system to provide flexible solutions to meet the needs of the various tasks. Settings can be preset for specific events or manually adjusted to accommodate certain tasks.

Design Implications

- Group specific lights together and consider daylighting from the south façade.
- Include a simple control system so that any event personnel can easily change between preset settings or manually adjust groups of lights.

Color Appearance (and Color Contrast) (Very Important)

The ballroom walls consist of a highly reflective paint, while the pilasters are a darker color decorated with wood trim. This contrast in color pattern highlights the architecture and differentiates the elements. The finishes must be rendered correctly to uphold the aesthetics of the space. The clothing that occupants wear will vary as well based on the function, so appropriate color rendering is important to ensure a pleasant appearance of clothing, skin tones, and food.

Design Implications

- Consider wall finishes and décor when selecting lamp types, CCT, and CRI.
- Utilize light sources with a high CRI and consider full spectrum lighting to guarantee solid color appearance.

Light Distribution on Surfaces (Important)

The lighting for public functions will differ than private functions to support an accurate psychological impression. Public events will require a uniform level of lighting on horizontal and vertical surfaces, while private events will involve non-uniform lighting modes and lower light levels to achieve the desired effect of intimacy. The vast difference in color between the walls and columns adds visual interest to the space and works well because the pattern corresponds with the architecture.

Design Implications

- Provide a flexible lighting and control solution that will emphasize different horizontal and vertical surfaces to help encourage a public and private feel.
- Provide a uniform layout of luminaires over the work plane.

Luminances of Room Surfaces (Important)

As mentioned previously, the color appearance of the ballroom finishes is very important. Wall washers increase the wall surface luminance and liven up the ballroom, while the darker pilasters interfere with the overall perception of brightness in the space. Higher vertical surface luminance is ideal for public, open events but is undesirable for a feeling of intimacy.

Design Implications

- Wall luminance of at least 30 cd/m² for public activities
- Provide proper distribution of lighting equipment for selected surfaces.
- Minimize dark areas at the top of walls and the ceiling by placing luminaires close to the walls to distribute more light evenly.

Modeling of Faces or Objects (Important)

The ballroom can accommodate large groups of people in highly social situations. It is important for the lighting system to enhance interaction among the occupants. Multidirectional and interreflected light from reflective walls and ceilings increases vertical illuminance on faces, which also renders faces more pleasantly with easier-to-read facial expressions.

Design Implications

- Avoid concentrated downlighting, which creates harsh facial shadows.
- Keep in mind multidirectional and interreflected lighting from walls and ceiling.

Points of Interest (Important)

The points of interest in the ballroom will vary due to the flexibility of activities. Temporary stages and podiums can be used, in which the lighting should draw attention by movement, contrast, or higher illuminance levels.

Design Implications

- Where stages and podiums can be located, add appropriate additional lighting equipment to create a point of interest.

Sparkle/Desirable Reflected Highlights (Very Important)

Tailored more towards private events with non-uniform lighting modes, it is important that the ballroom is capable of adding small points of high luminance to enhance visual interest.

Design Implications

- Consider small candles for banquet tables or luminaires that spark interest and bring excitement to the space.

ASHRAE 90.1 – 2004 Power Density Allowance

Space-by-Space Method (Table 9.6.1)

- Conference/Meeting/Multipurpose: 1.3 W/SF
- An increase in the interior lighting power allowance is permitted for spaces in which lighting is specified to be installed in addition to the general lighting for the purpose of decorative appearance (chandelier-type or sconces), provided that the additional power shall not exceed 1.0 W/SF (ASHRAE 90.1 – Section 9.6.3.a).
- Total Lighting Power Density Allowance: 2.3 W/SF

Room Area: 4,292 SF

Lighting Power Allowance: 5,580 W + 4,292 W = 9,872 W

Evaluation and Critique

The ballroom does not dissatisfy with regards to decorative lighting and materials. There are a variety of luminaires, which allows the space to be very flexible for the different functions. The large quantity of recessed downlights provide varying uniformity throughout the space and also clutter the ceiling. There is a light in almost every ceiling tile of the ballroom, which is distracting and takes away from the architecture of the space. Areas of darkness exist where architectural bulkheads are present above. The continuous patterns from the wall washers on the walls and acoustical panels add peripheral lighting and open up the space.

The quantitative data and renderings from AGi32 are shown on the following pages with all luminaires turned on at full output, even though the space would not likely have all the lighting turned on at one time. The average illuminance of 65 fc at a work plane height of 2'-6" seems excessively high for the events that will be held in the ballroom. IESNA recommends 30 fc for meetings, fairs, and classrooms, so the ballroom may be over-illuminated for the specific tasks.

The ballroom fails to meet ASHRAE-90.1 power density requirements. High wattage CFLs and custom luminaires are the most responsible cause for the lighting power density to exceed 2.3 W/SF even with the decorative allowance.

Ballroom Lighting Power Density			
Type	Quantity	Input W/Luminaire	Total Watts
C4D	141	43.2	6091
C4DW	22	43.2	950
D	10	15	150
Q	6	110	660
W2	6	345.6	2074
WAD	24	39	936
Total Watts			10861
Total SF			4292
LPD			2.53 W/SF

Table 8: Ballroom LPD Calculation

Lighting Calculations for Current Design

Luminaire Designation	Maintenance Category	Cleaning Interval	Initial Lumens per Luminaire	Mean Lumens per Luminaire	LLD	LDD	RSDD	BF	Total LLF
C4D	IV	Clean 12 month	3200	2690	0.84	0.92	0.98	0.95	0.72
C4DW	IV	Clean 12 month	3200	2690	0.84	0.92	0.98	0.95	0.72
D	V	Clean 12 month	900	755	0.84	0.92	0.98	1.00	0.76
Q	V	Clean 12 month	3000	2030	0.68	0.92	0.98	1.00	0.62
W2	V	Clean 12 month	3200	2690	0.84	0.92	0.91	0.95	0.67
WAD	V	Clean 12 month	1350	1280	0.95	0.92	0.98	1.00	0.86

Table 9: Classroom Light Loss Factors

Sample Light Loss Factor Calculations

Lamp Lumen Depreciation

F42TBX/835/A/ECO

$$\text{LLD} = \text{mean lumens} / \text{initial lumens} = 2690/3200 = \mathbf{0.84}$$

Luminaire Dirt Depreciation

*Using new procedure from IESNA Lighting Handbook, 10th edition

Environment – Clean

Luminaire – Other

Case – W

$$\text{Chart value based on 12 month cleaning cycle} = \mathbf{0.92}$$

Room Surface Dirt Depreciation

$$\text{Room Cavity Ratio} = [(5*10.5)*(83.1+51.6)] / [(83.1*51.6)] = 1.55$$

Degree of dirt condition – Clean

Cleaning Cycle – 12 months

Expected dirt depreciation = 12%

Luminaire distribution type – Direct

$$\text{RSDD} = \mathbf{0.98}$$

Ballast Factor – Lutron Hi Lume for 42W CFL = **0.95**

AGi32 Calculation Summary

All Lights On 2'-6" Work Plane (Desks/Tables)	
Average Illuminance (fc):	65.39
Maximum Illuminance (fc):	80.00
Minimum Illuminance (fc):	41.10
Maximum : Minimum:	1.95
Uniformity:	1.35

Table 10: Work Plane Calculations

AGi32 Calculations and Renderings

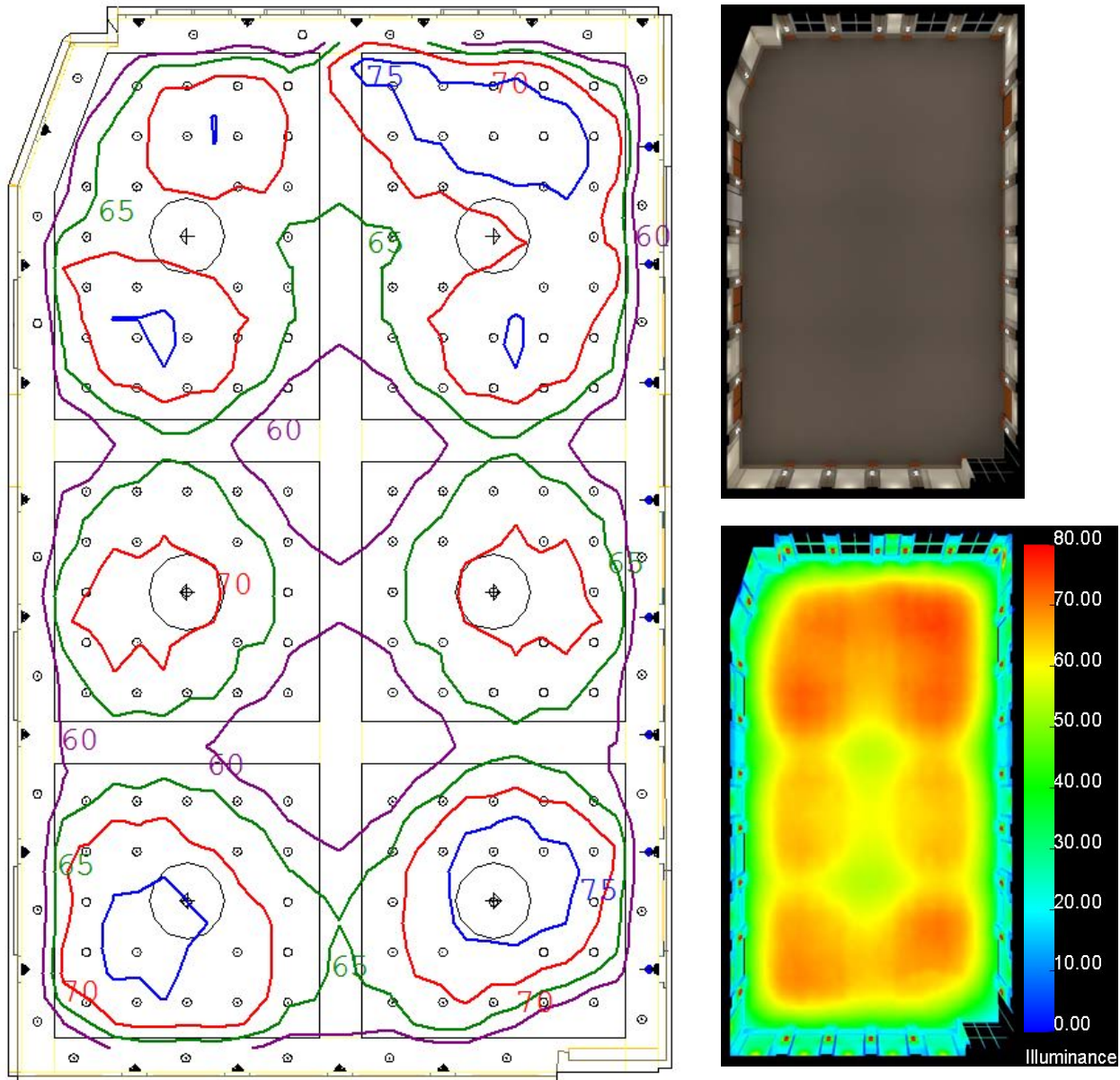

Figure 22: Ballroom Illuminance Contour Plat, RGB, and Pseudo Rendering

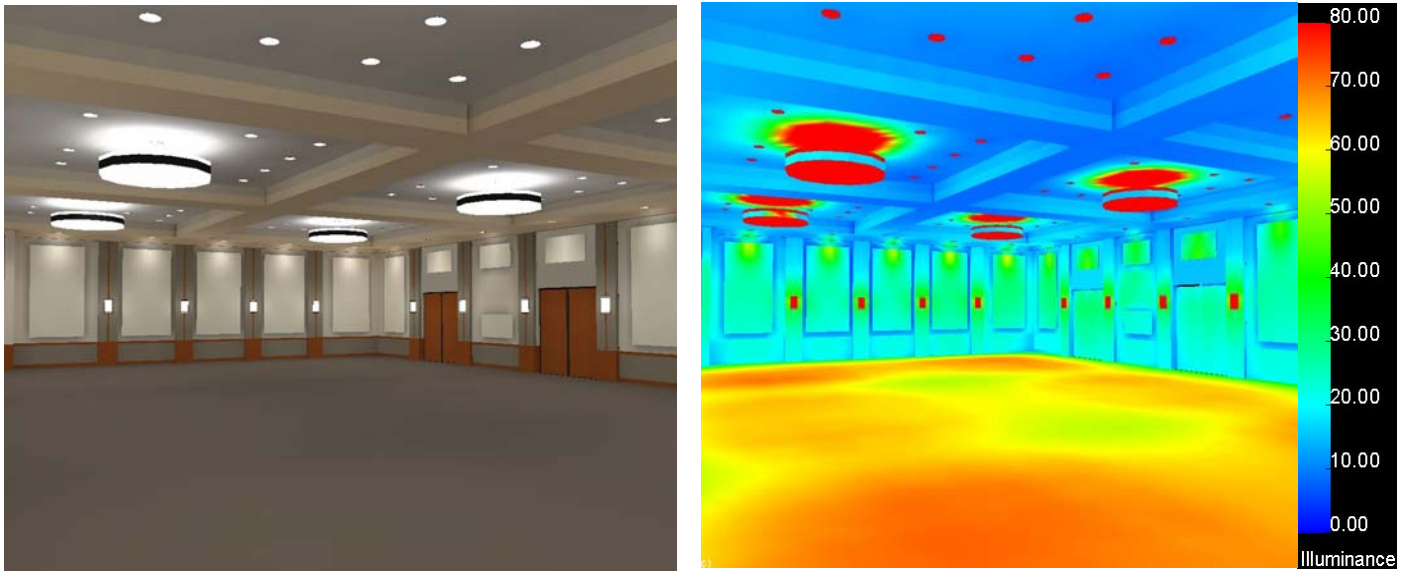

Figure 23: RGB and Pseudo Rendering Looking Northeast

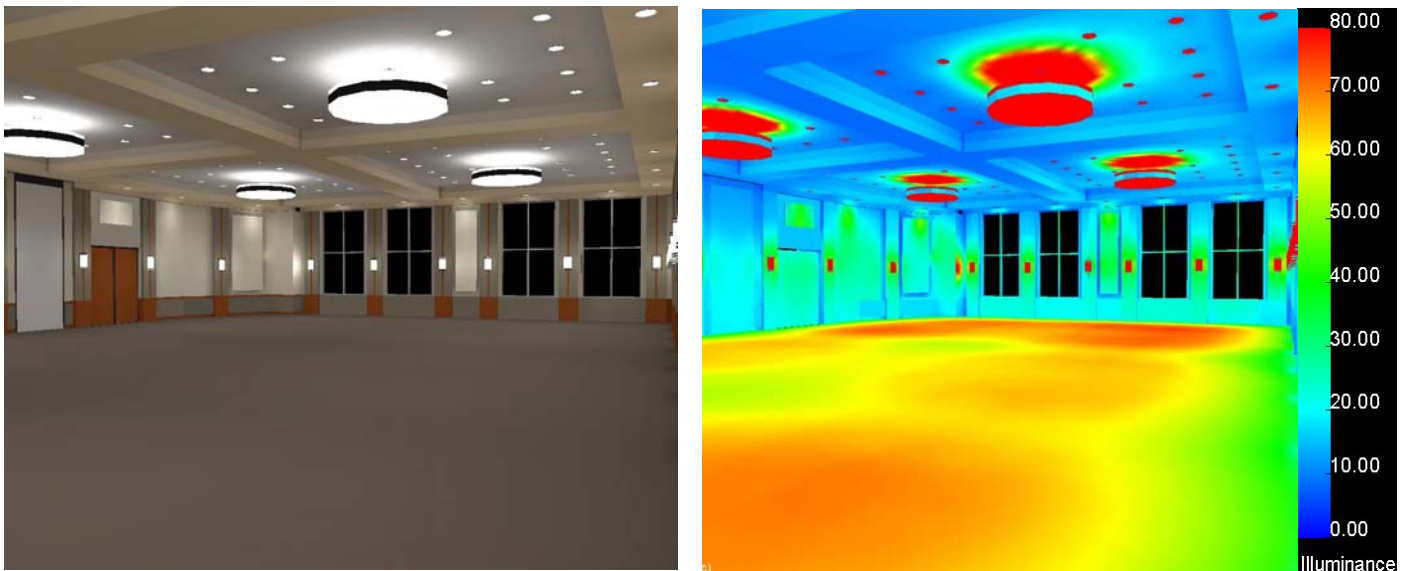

Figure 24: RGB and Pseudo Rendering Looking Southeast

Circulation Space | Main Lobby

Existing Room Conditions

Description

The two-story lobby serves as the central hub for the Campus Center. Located at the north entrance of the building, the lobby ties into the grab-and-go dining facility, student lounges, and elevator lobby and also adjoins to the adjacent School of Nursing building. The stair leads to the pre-function lobby and ballroom, while the curved concourse guides occupants to a hot dining facility.

Furniture and Accessories

Because the lobby guides occupants to a variety of spaces, only a security desk and information desk interfere with direct circulation. The security desk is utilized to sign-in all occupants as they enter the Campus Center. The information desk located near the elevator lobby serves as an information and guidance tool and incorporates decorative panels and flat screen televisions on the back wall. The space is very colorful and welcoming with many decorative features including the columns and stairs.

Area 2,270 SF

Dimensions Approximately 63'-0" x 36'-0", with a ceiling height of 31'-10"

Activities/Tasks

Activities and visual tasks vary and are tailored to individual areas within the lobby. Tasks at the security and information desks will involve reading, writing, and VDT use. The elevator lobby orients people to the elevators and lighting helps occupants read signage more clearly. The remainder of the lobby will include general activities to guide occupants to a particular destination.

Materials







Surface	Material	Color	Reflectance
Ceiling	Metal Panel: Armstrong, Wood Looks, 2'x2' with fiberglass infill panels	Cherry 	0.16
Ceiling	Metal Panel: Armstrong, Metalworks, microperforated with fiberglass infill panels	Gun Metal 	0.22
Walls (N, W)	Paint: Benjamin Moore 2154-60	Filtered Sunlight 	0.83
Columns	Paint: Benjamin Moore 2158-30	Delightful Golden 	0.36
Floor	Ceramic Floor Tile: Daltile Colorbody Forcelan, 18"x18"	Ardesia 	0.07
Floor	Granite Floor Tile: Flame finish granite accent	Absolute Black 	0.00

Table 11: Lobby Finishes

Lobby Floor Plans, Elevations, and Section

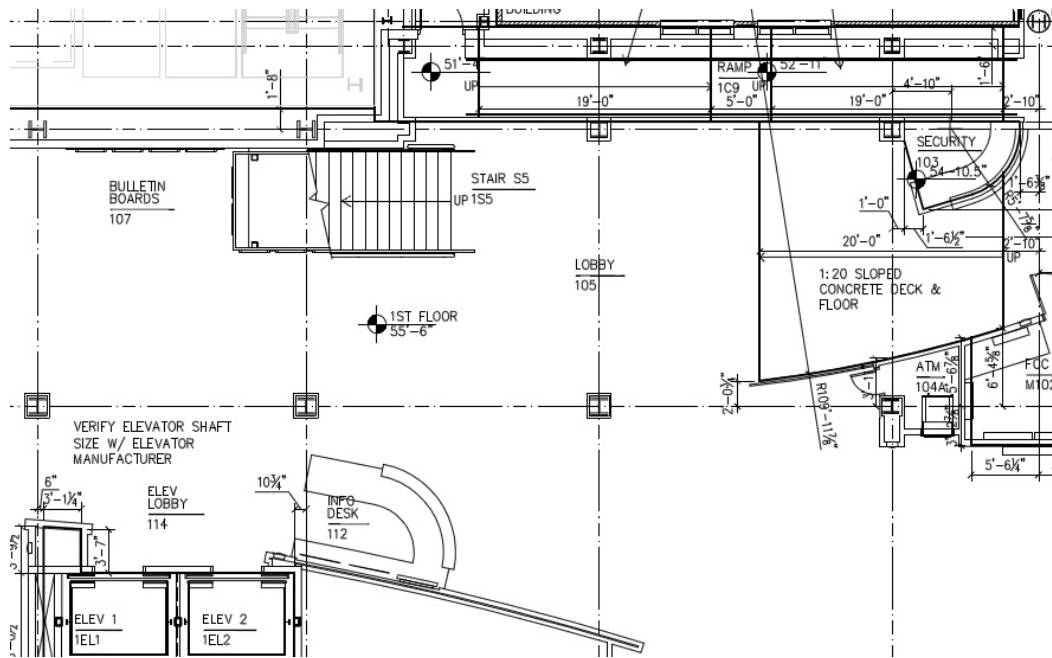

Figure 25: Lobby First Floor Plan (NTS)

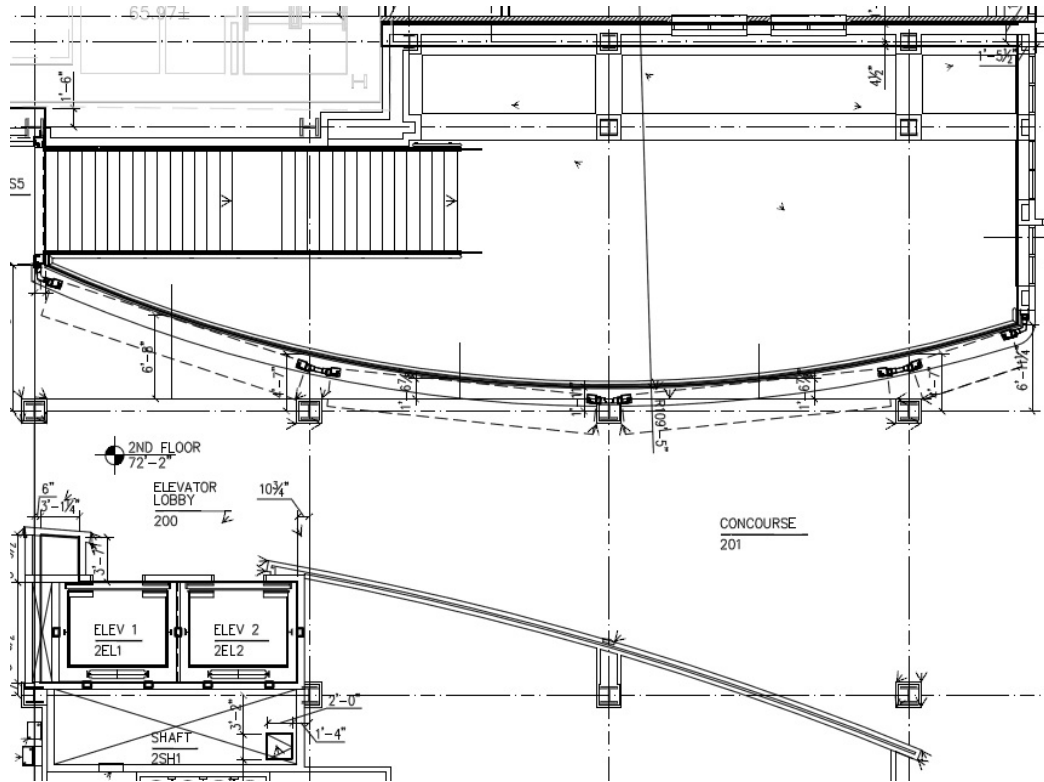

Figure 26: Lobby Second Floor Plan (NTS)

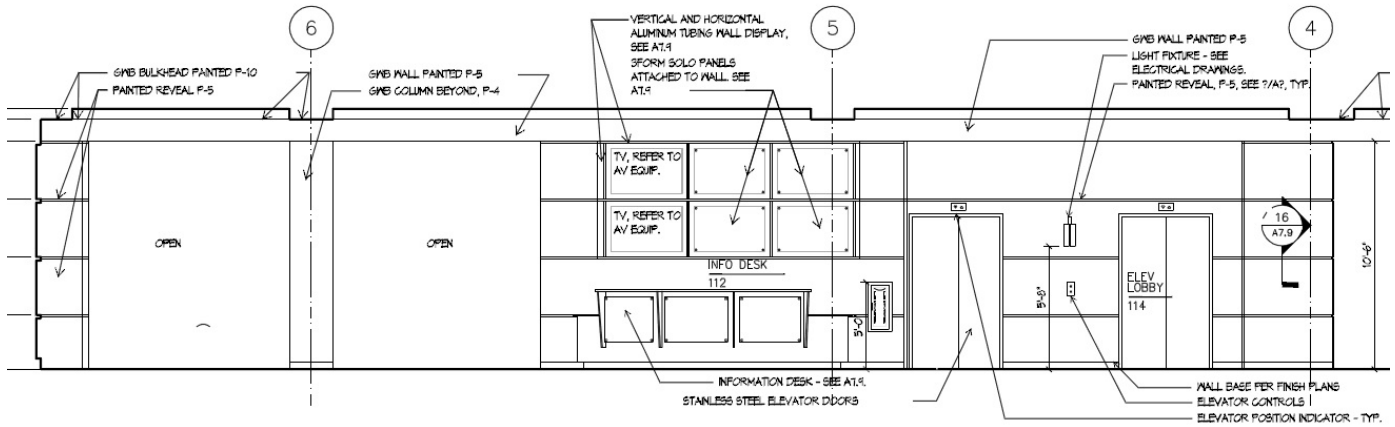

Figure 27: Lobby East Elevation (NTS)



Figure 28: Lobby N-S Section (NTS)

Lobby Photographs

Figure 29: Lobby looking North



(a)



(b)



(c)

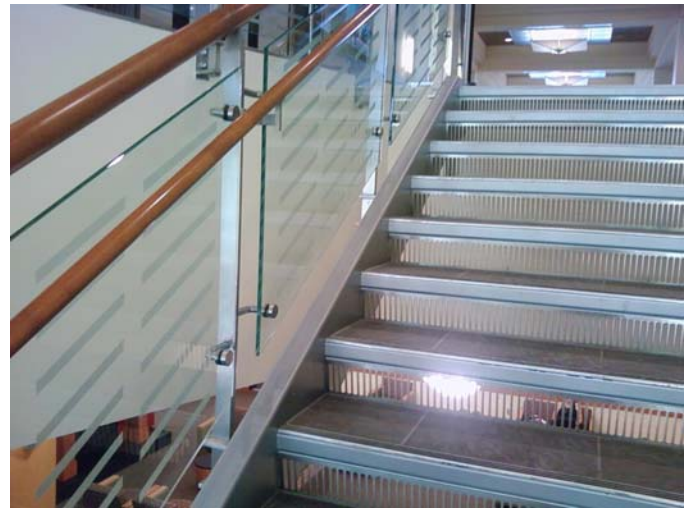

(d)

Figure 30: Lobby from various views

Existing Lighting Conditions

Lighting Layout

Lighting in the lobby is very decorative. The first floor utilizes custom linear fluorescent wall sconces on the columns and MR16 track lighting over the information desk. The majority of the general lighting for the lobby and stair comes from the second floor ceiling. Large, 7'x7' custom pendants spaced 12'-0" on center illuminate the metal ceiling panels. The same wall sconces are present on the second floor columns and CFL downlights spaced 6'-0" on center supply additional light to the open first floor.

Lighting Equipment

Two ultrasonic technology occupancy sensors control the lighting based on daylight levels from the west wall on the first floor. A single photocell located in the second floor ceiling is connected to the Building Automation System for control of lighting.

Type	Mounting	Luminaire Description	Manufacturer and Catalog Number	Lamp Number and Type	Voltage
C	Ceiling Recessed	6" aperture open reflector downlight with clear reflector and a semi-diffuse low iridescent finish	Gotham Lighting AFV-32TRT-6AR-LD	(1) 32W TRT CFL	277
C4	Ceiling Recessed	8" aperture open reflector downlight with clear reflector and a semi-diffuse low iridescent finish	Gotham Lighting AFV-42TRT-8AR-LD	(1) 42W TRT CFL	277
W1	Pendant	7' x 7' custom pyramidal luminaire with opal acrylic glass panels	Winona Lighting Custom Type 2	(12) 42W CFL (2) 26W CFL	277
WA	Wall Surface	1' x 3' custom wall sconce with opal acrylic glass panels	Winona Lighting Custom Type 3	(2) 17W T8 Fluorescent	277
WH (track)	Ceiling Suspended	Single circuit field bendable and cuttable lighting track with clear insulator in satin nickel finish (track, remote transformer, powerfeed canopy, power extender)	Tech Lighting 700-MOA-LENGTH-S (Track) 700AT300T-277 (Xfmr) 700MPP4C02S (powerfeed canopy) 700MOPS (extender)	--	--
WH (head)	Track	4" length MR16 lamp holder with 360 degree rotatable head, 260 degree pivot in satin nickel finish with frosted white round glass shield and 6" pendant length (Info Desk)	Tech Lighting 700-MO-AE-6-S (head) 700MR16G-F- ALUMINUM (glass shield)	(1) 50W MR16	277

Table 12: Lobby Existing Lighting Equipment

Daylighting

Four large windows (two on first floor, two on second floor) provide daylight into the lobby from the west façade, which is open to a courtyard in front of the School of Nursing building. Because of the size and proximity of nearby structures, it is unlikely that the space will receive direct sunlight until late afternoon or closer to sunset, which may be undesirable for occupants.

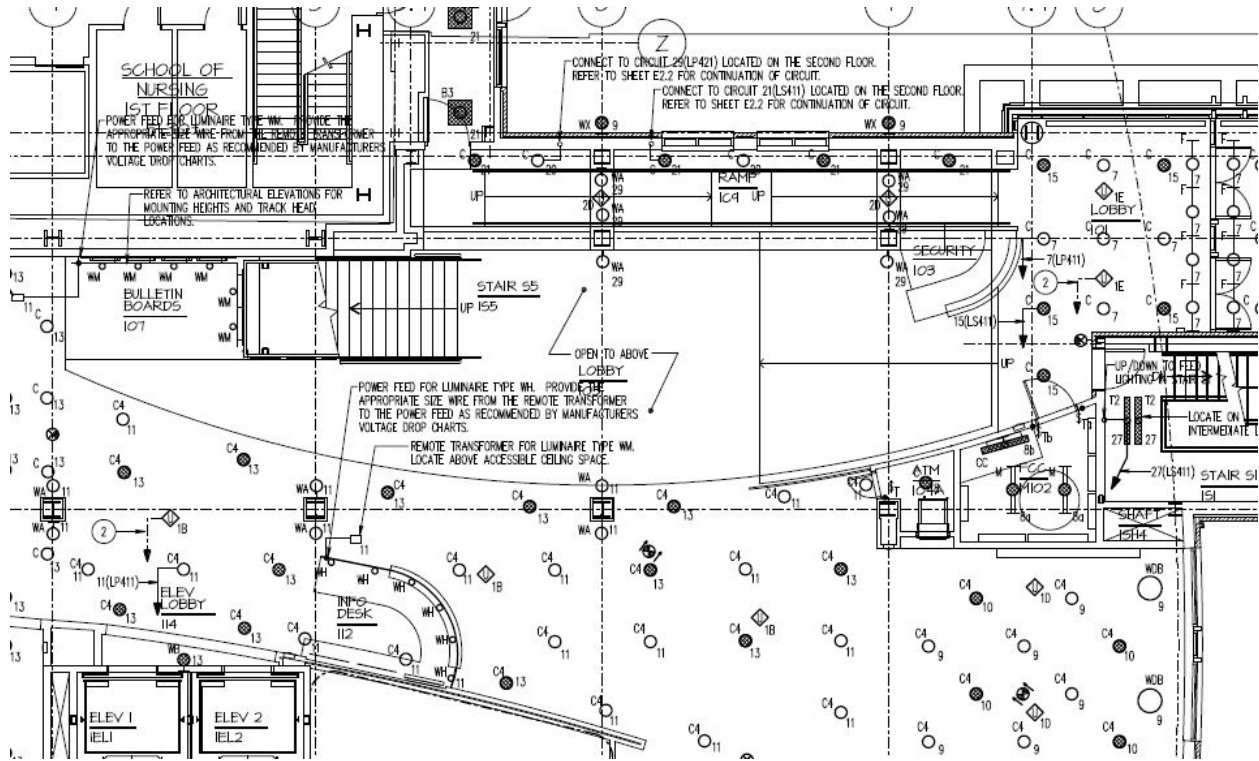

Figure 31: 1st Floor Lobby Lighting Plan (NTS)

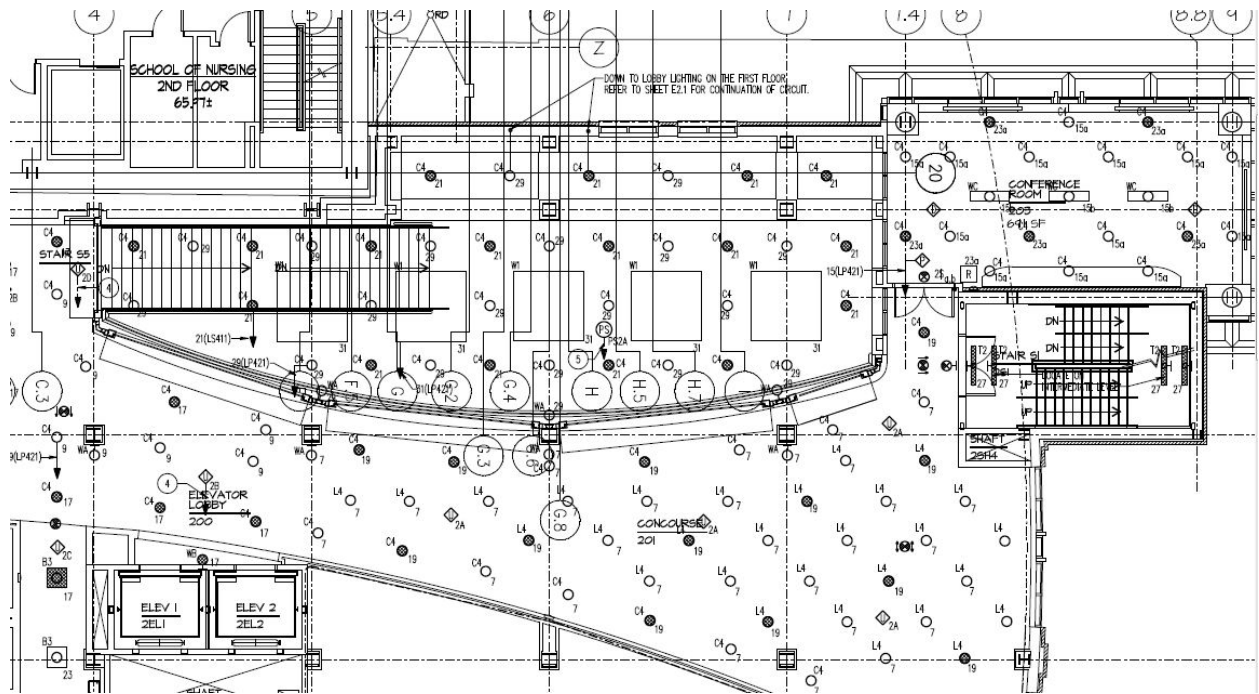

Figure 32: 2nd Floor Lobby Lighting Plan (NTS)

Lighting Design Considerations and Criteria

IESNA Lighting Design Guide Space Type

Offices (Lobbies, lounges, and reception areas)
Educational Facilities (Corridors)
Service Spaces (Stairways and Corridors)

The lobby includes multiple space types. Considerations, criteria, and light levels will vary for the specific areas, including general lighting, security and information desks, stairs, and elevator lobby.

IESNA Illuminance Recommendations

Offices (lobbies, lounges, and reception area)

- 10 fc (horizontal)
- 3 fc (vertical)

Educational Facilities (Corridors)

- 10 fc (vertical)

Service Spaces (Stairways and Corridors)

- 5 fc (horizontal)

Psychological Impression

The lighting design for the lobby must be inviting and spacious. The large, two-story space should be vibrant and bright with openness to the outdoors.

Design Implications

- Take into consideration daylighting from the west wall to provide as much natural light as possible into the space.
- Consider decorative features to liven up the space and make occupants feel welcome.

Daylighting Integration and Control (**Very Important**)

Daylighting is important for psychological and physiological reasons. Occupants in the nearby lounge and dining space and people just walking by can enjoy the benefits of quality daylight that can also result in significant energy savings. It is possible for the lobby to provide recommended ambient illumination levels throughout most of the day. As the sun sets in the late afternoon, issues of direct penetration may occur and will need to be accounted for in the design.

Design Implications

- Dimmable luminaires will be necessary for proper integration with electric lighting.
- Consider shading devices and photosensors for overly bright days and late afternoon sunlight.

Appearance of Space and Luminaires (Very Important)

The lobby is the first space occupants will encounter, so a positive impression is important. After entering the lobby, occupants have a variety of circulation paths to choose. The security desk and information desk provide visual cues that will assist with orientation and circulation throughout the space. Lighting these areas with extra emphasis and brightness draws the attention of the eye and aids in circulation. Occupants can also be guided to the dining facility or up the stairs to the second floor.

Design Implications

- Enhance the architecture of the lobby with appropriately selected and placed lighting equipment.
- Provide emphasis to certain areas of the lobby to aid in circulation patterns.

Direct Glare (Important)

Direct glare from light sources and daylight reduces visibility and comfort as occupants walk through the lobby. Staff at the information desk face towards the west where direct sun may enter the west facade late in the afternoon. Safe levels of light should be provided with appropriate luminaires to assist circulation without causing distractions.

Design Implications

- Provide shading devices on the west glazing for afternoon sun penetration.
- Consider glare limiting luminaires that won't interfere with circulation patterns.

Light Distribution on Surfaces (Important)

Distribution on surfaces in the lobby should be uniform. General, open areas should avoid patterns of light, which may confuse occupants and result in shadowing. The security and information desks should be uniform for staff members to perform their tasks. The main stair to the second level should have a regular illuminance pattern to correspond with the architecture of the steps to aid in visibility.

Design Implications

- Consider each area of the lobby individually, but keep in mind patterns and features to bring the lighting design together.

Luminances of Room Surfaces (Important)

The lobby includes a variety of finishes and textures that should be considered in the lighting design. The eye is drawn to areas of higher brightness, so higher luminance is acceptable for the information desk and elevator lobby. The open area should be less bright and considered a corridor to get occupants where they need to be in the Campus Center.

Design Implications

- Consider luminance ratios for staff members at security and information desks.
- Draw attention to information desk and the architectural stair element.

Color Appearance (and Color Contrast) (Important)

The color rendering of the various material finishes and textures is important, such as the granite floor, golden columns, and steel stairs. Light sources with high CRI should be selected to make all surfaces appear with good quality. Color should be neutral or cooler to correspond with daylight integration.

Design Implications

- Select light sources with a high CRI of at least 85.
- Consider daylight when selecting CCT of light sources.

ASHRAE 90.1 – 2004 Power Density Allowance

Space-by-Space Method (Table 9.6.1)

- Lobby: 1.3 W/SF
- An increase in the interior lighting power allowance is permitted for spaces in which lighting is specified to be installed in addition to the general lighting for the purpose of decorative appearance (chandelier-type or sconces), provided that the additional power shall not exceed 1.0 W/SF (ASHRAE 90.1 – Section 9.6.3.a).
- Total Lighting Power Density Allowance: 2.3 W/SF

Room Area: 2,270 SF

Lighting Power Allowance: 2,951 W + 2,270 W = 5,221 W

Evaluation and Critique

The existing lighting solution in the lobby addresses few of the considerations and criteria mentioned above. A lobby can establish the main design theme for a building. The lighting is very decorative and ornate, which is seen throughout the rest of the Campus Center, but it does not conform to the curved elements of the space. The curved ceiling and concourse are important design elements in which the lighting should accentuate. The large square pendants consume a large amount of power and make the curved elements appear more linear. This idea also goes along with the consideration of enhancing the architecture of the lobby, creating a welcoming first impression.

Occupancy sensors and a photocell are used for lighting control and daylight integration. Currently, no shading devices are present on the west windows to prevent the possibility of direct glare. Also, the second floor windows above the security desk are open to the conference room in the background. The glass enclosed conference room can become very bright and cause the viewing window to the lobby to appear with high luminance causing discomfort to occupants.

All areas of the lobby should be easily recognizable. The reception desk has special architectural features and lighting to draw attention. The dining area is a large, open area viewed from the lobby, and a student lounge can easily be seen beyond the main stair.

The existing design exactly meets the ASHRAE-90.1 lighting power density requirements with the additional decorative allowance.

Lobby Lighting Power Density			
Type	Quantity	Input W/Luminaire	Total Watts
C	9	34	306
C4	62	43.2	2678
W1	5	575	2875
WA	16	39	624
WH	6	50	300
Total Watts			6783
Allowable Watts			5221
LPD			1.30 W/SF

Table 13: Lobby LPD Calculation

Outdoor Space | Building Façade

Existing Façade Conditions

Description

The north building façade is comprised of two main components to conform to the surrounding campus architecture. A 24”x12”x4” synthetic stone wall veneer is used for the first floor and 4” face brick is used for the second and third floor. An additional material, precast concrete, is used for the exterior structure of the natatorium located on the fourth floor and extending to the fifth floor. The extensive use of glass allows abundant daylight into large common areas of the building, such as dining seating, student organization offices, and the indoor pool.

Activities/Tasks

The Campus Center provides openness to Lombard Street and adjoins the surrounding courtyard and plaza areas of the adjacent buildings. The main task is to guide occupants into and past the building safely at night. There are numerous planters and benches in the small plaza area leading to the main northwest entrance. The main seating and gathering area, however, is the larger plaza of the Health Sciences Library and the open courtyard in front of the School of Nursing.

Materials



Surface	Material	Color	Reflectance
Low Façade	24”x12”x4” synthetic stone veneer		0.73
Mid Façade	4” face brick		0.18
High Façade	Precast concrete		0.71
Glazing (G1)	1” insulating, clear, low-e glass	--	
Glazing (G3)	1” insulating spandrel glass used to separate floors	--	

Table 14: Building Façade Finishes

Building Façade Elevations and Sections

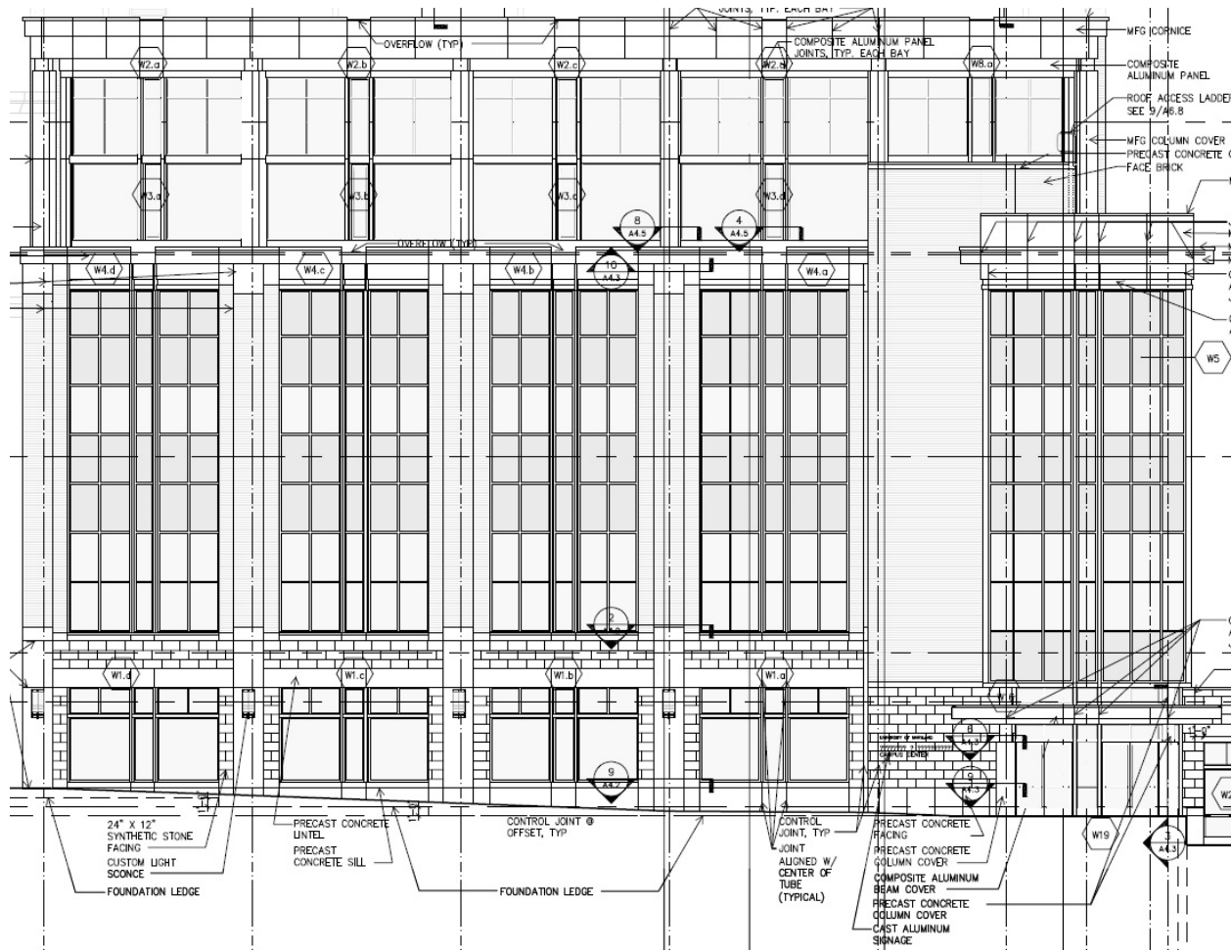

Figure 33: North Elevation (NTS)

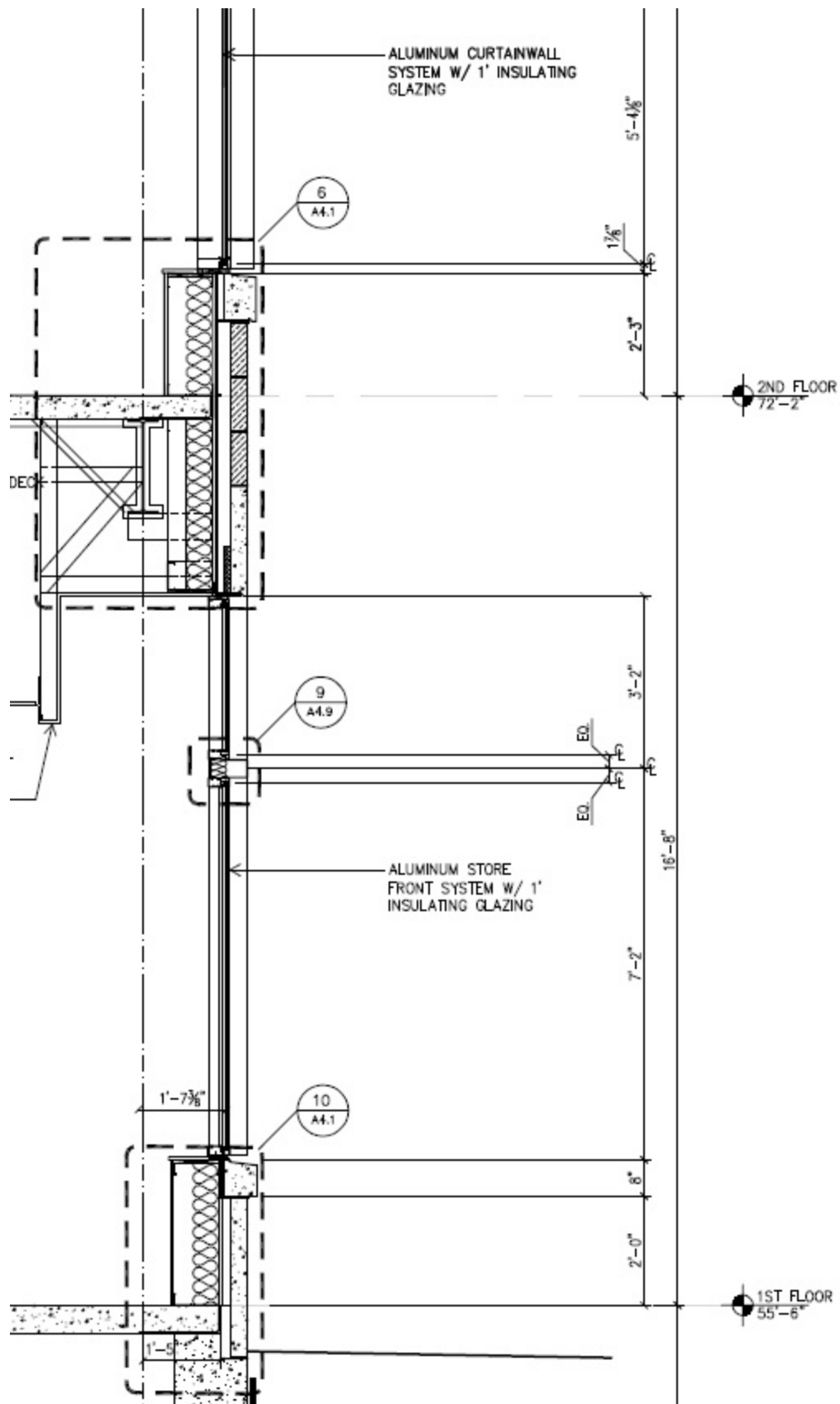

Figure 34: Exterior Section 1st-2nd (NTS)

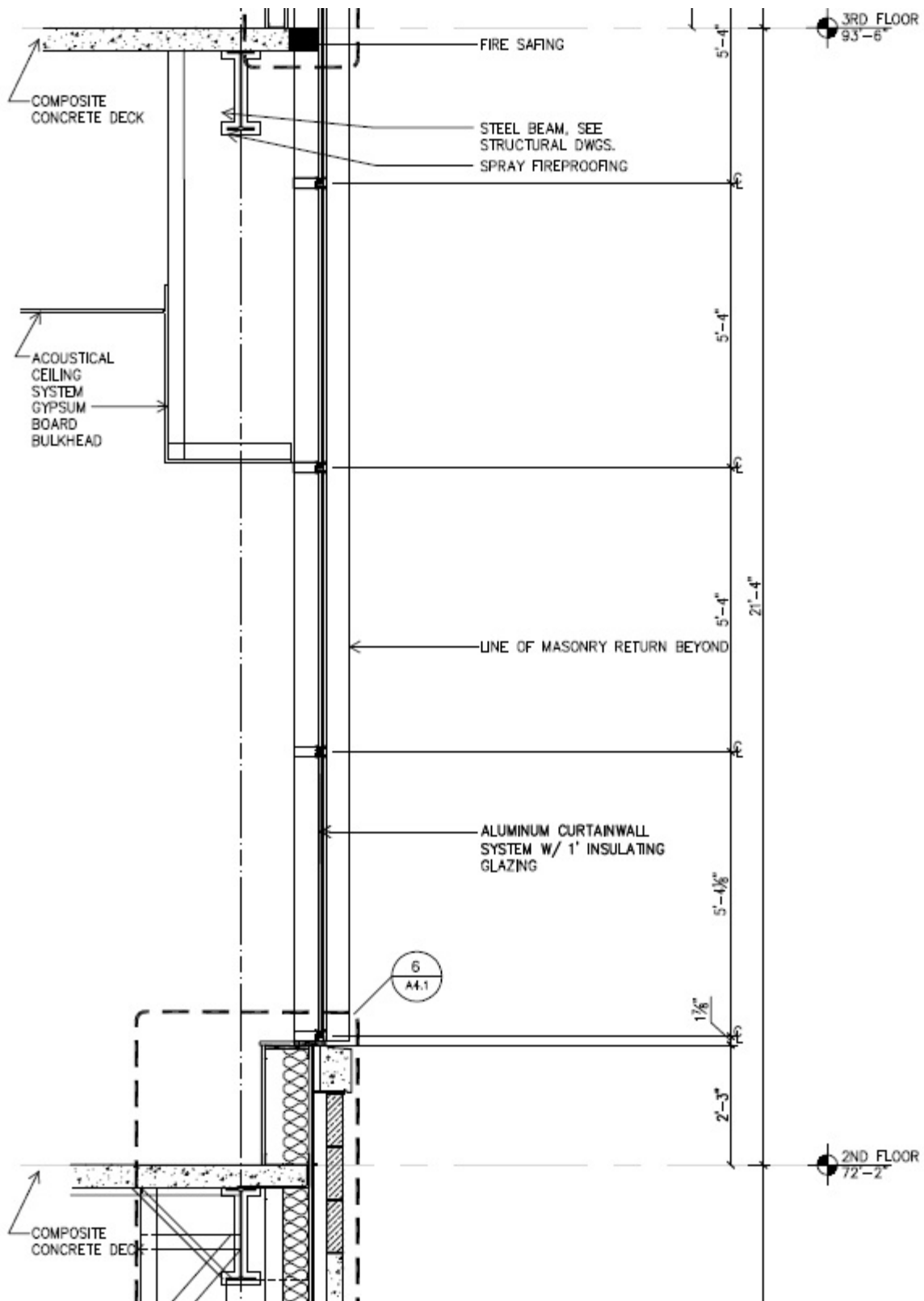

Figure 35: Building Section 2nd-3rd (NTS)

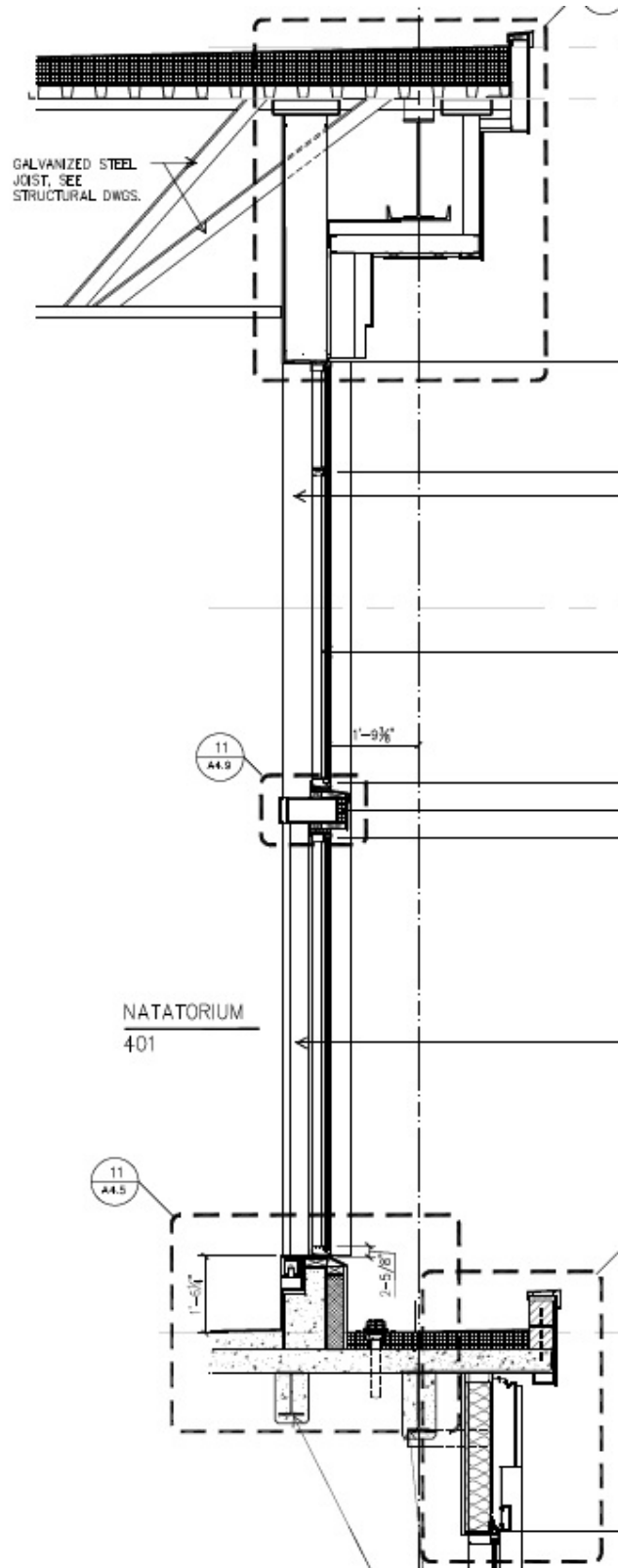
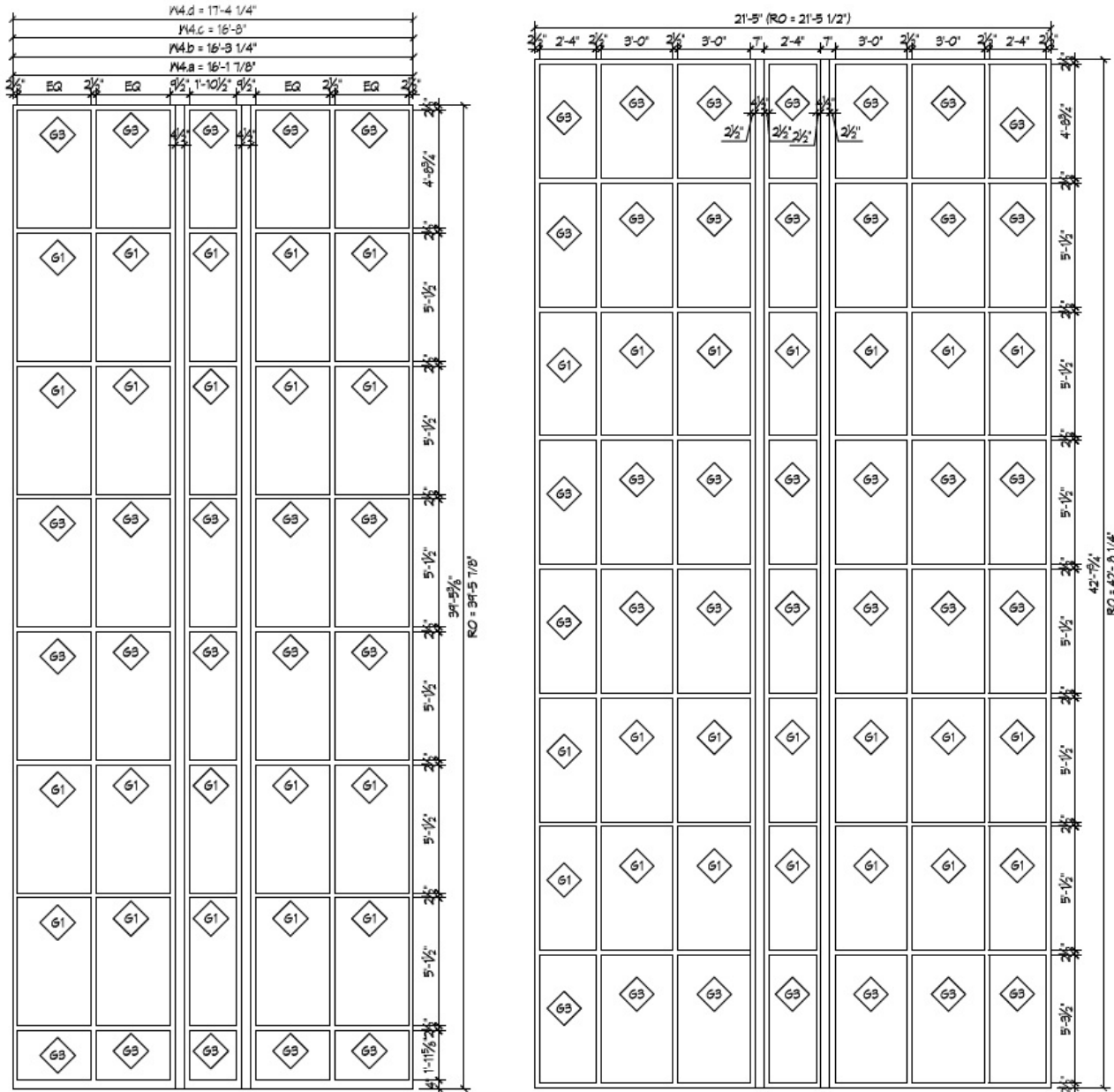

Figure 36: Building Section Natatorium (NTS)



GLAZING SCHEDULE



-  1" INSULATING CLEAR LOW-E GLASS (TYPICAL EXTERIOR GLAZING)
-  1" TEMPERED INSULATING CLEAR LOW-E GLASS (FOR GLAZING IN AND ADJACENT TO DOORS)
-  1" INSULATING SPANDREL GLASS W/ 3-1/2" BATT INSULATION

Figure 37: North Façade Glazing with Panel Type and Schedule

Building Façade Photographs

Figure 38: Schematic Rendering



Figure 39: Building Façade Close-Up

Existing Lighting Conditions

Lighting Layout

The lighting for the façade is minimal. Four linear fluorescent, custom wall sconces are located on the columns to provide decorative light to guide people into and past the Campus Center. The entry canopy utilizes 2’ and 4’ linear fluorescent luminaires that supply additional light to help guide occupants to the main entrance.

Type	Mounting	Luminaire Description	Manufacturer and Catalog Number	Lamp Number and Type	Voltage
WX	Wall Surface	1'-6" x 4'-6" custom exterior wall sconce with white acrylic lens	Winona Lighting Custom Type 1	(2) 39W T5HO Fluorescent	277
H2	Ceiling Surface	2' length, wet location, lensed high abuse luminaire with polycarbonate lens and brushed stainless steel housing	Kenall Lighting R5-24-2-17-CW-277-0 156-BSS-WL	(2) 17W T8 Fluorescent	277
H4	Ceiling Surface	4' length, wet location, lensed high abuse luminaire with polycarbonate lens and brushed stainless steel housing	Kenall Lighting R5-48-2-32-CW-277-0 156-BSS-WL	(2) 32W T8 Fluorescent	277

Table 15: North Façade Existing Lighting Equipment

Facade Plans and Elevation

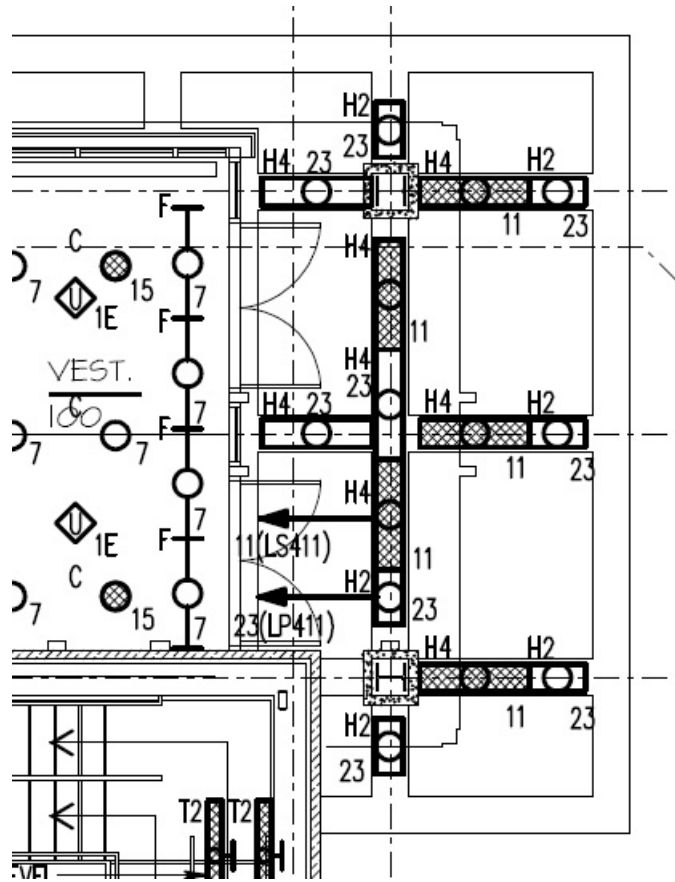

Figure 40: Entry Canopy Lighting Plan (NTS)

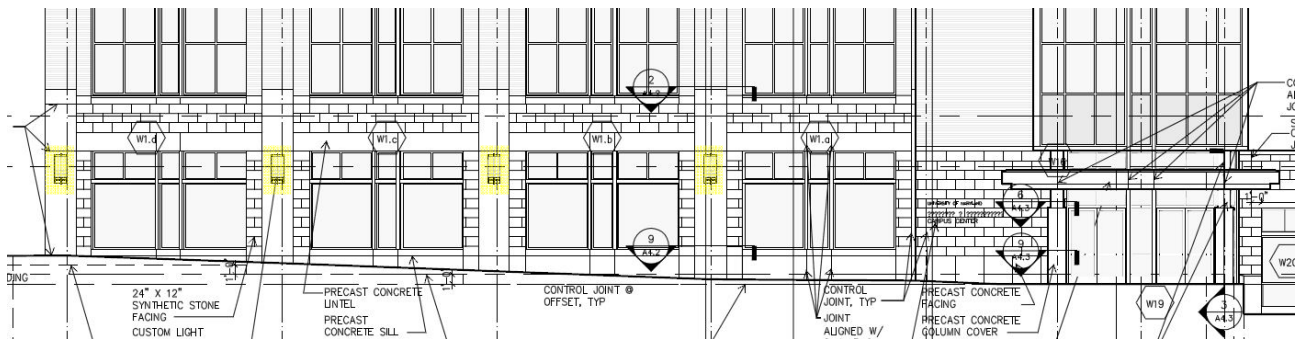

Figure 41: North Elevation (NTS)

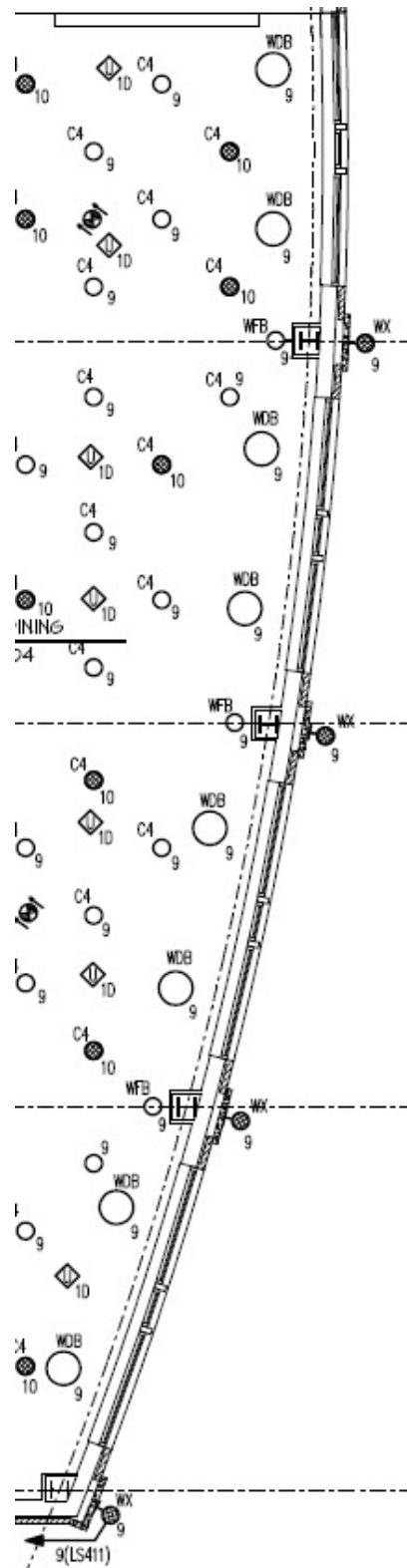

Figure 42: First Floor Exterior Lighting Plan

Lighting Design Considerations and Criteria

IESNA Lighting Design Guide Space Type

Building Exteriors, Entrances, Active (pedestrian/conveyance)

IESNA Illuminance Recommendations

Building Exteriors, Entrances, Active (pedestrian/conveyance)

- 5 fc (horizontal)
- 3 fc (vertical)

Psychological Impression

The lighting design for the exterior of the Campus Center should be welcoming. It should be safe and inviting to all students, faculty, staff, and visitors.

Design Implications

- Provide adequate light levels leading up to the main entrance which is highlighted.

Light Pollution/Sky Glow/ Trespass (**Very Important**)

The Campus Center is directly across the street from the UM Medical Center. Exterior lighting that could cause problems for incoming safety helicopters should be avoided. The site is also part of Baltimore City's Urban Renewal Plan, which aims for more sustainable building practices.

Design Implications

- Use full cutoff luminaires to limit trespass and sky glow.
- Consider the adjacent buildings and UM Medical Center when selecting equipment.

Emphasize UMB Campus, Architecture, and Materials (**Very Important**)

The Campus Center is the heart of the UMB campus. The exterior lighting should emphasize the modern architecture and materials, while creating a visually appealing building. The lighting should also enhance the campus by making the Campus Center a central landmark.

Design Implications

- Utilize equipment that will highlight important architectural features.

Glare Issues (**Very Important**)

The exterior lighting of the facade should not be overly bright. Nighttime adaptation to light is different than during the day, so extremely luminous sources may be discomforting to occupants walking by to enter the building.

Design Implications

- Provide lighting equipment to that direct glare from sources will be avoided.
- Consider surface materials to limit reflected glare.

Lighting Controls (Very Important)

Exterior lighting should be on a programmable time clock or daylight sensor. This will save significant amounts of energy and will also help increase lamp life.

Design Implications

- Use a time clock or connect luminaires to the Campus Center dimming system.

ASHRAE 90.1 – 2004 Power Density Allowance

Main Entry (Tradable)

- 30 W/linear foot of door width

Walkways less than 10 feet wide (Tradable)

- 1.0 W/linear foot

Plaza Areas (Tradable)

- 0.2 W/SF

Canopies and Overhangs (Tradable)

- 1.25 W/SF

Building Facade (Non-Tradable)

- 0.2 W/SF for each illuminated wall or surface or 5.0 W/linear foot for each illuminated wall or surface length

Exterior Building Grounds Lighting - All exterior building grounds luminaires that operate at greater than 100watts shall contain lamps having minimum efficacy of 60 lm/w unless the luminaire is controlled by a motion sensor.

Evaluation and Critique

The existing lighting for the exterior facade of the Campus Center is plain and minimal. Only four custom wall sconces illuminate the lower facade and set the tone for the interior lighting design. The face brick and precast concrete columns of the upper floors receive no light to highlight the surfaces or textures. This may be due to the hospital across the street, but it is possible to illuminate these surfaces without producing light pollution or sky glow. This is a new, modern facility that marks the heart of the UMB campus and it should be displayed as such.

The entry canopy uses surface mounted, linear fluorescent luminaires. This is not the best way to attract occupants to the building. Architectural elements such as the columns should be considered to add emphasis to the main entry.

References

1. ANSI/ASHRAE. (2004). Standard 90.1 - 2004, Energy Standard for Buildings Except Low-Rise Residential Buildings. Atlanta, GA: American Society of Heating Refrigeration and Air Conditioning Engineers, Inc.
2. The IESNA Lighting Handbook: Reference and Application. Illuminating Engineering Society of North America, 9th Edition. July 2000.